

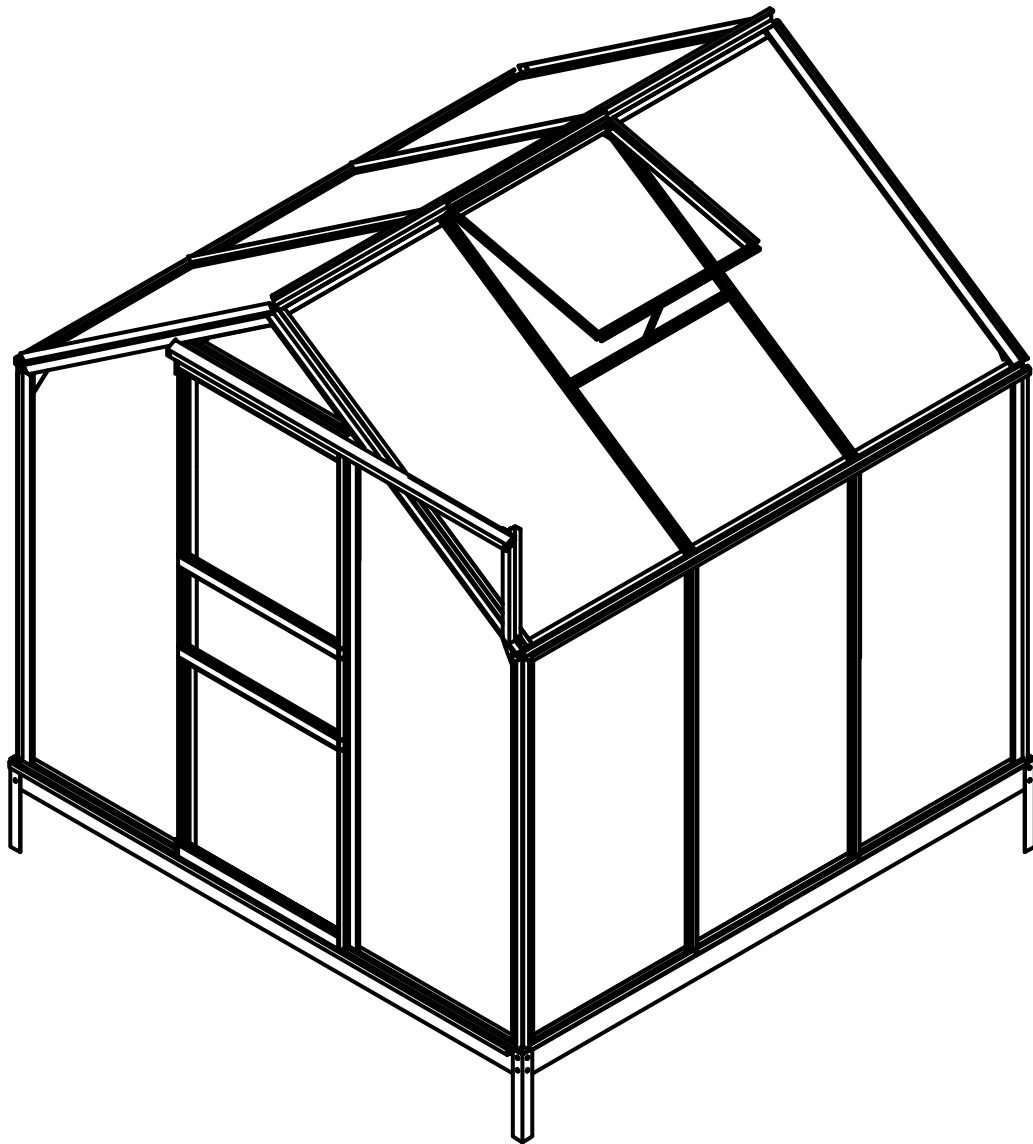

INbfc002V03_GL

845-058



ΕΓΧΕΙΡΙΔΙΟ ΣΥΝΑΡΜΟΛΟΓΗΣΗΣ & ΟΔΗΓΙΩΝ

ΓΙΑ ΤΗΝ ΠΡΟΛΗΨΗ ΤΡΑΥΜΑΤΙΣΜΟΥ, ΔΙΑΒΑΣΤΕ ΚΑΙ ΚΑΤΑΝΟΗΣΤΕ ΤΙΣ ΟΔΗΓΙΕΣ ΣΥΝΑΡΜΟΛΟΓΗΣΗΣ ΤΟΥ ΘΕΡΜΟΚΗΠΙΟΥ ΠΡΙΝ ΤΗ ΧΡΗΣΗ.

Σημειώσεις:

1. Χρειάζονται περίπου 1-2 ώρες για να συναρμολογηθεί το θερμοκήπιο από 2-3 άτομα.
2. Η προστατευμένη από την υπεριώδη ακτινοβολία πλευρά του φύλλου καλύπτεται με μεμβράνη λευκού οπαλίου και πρέπει να είναι στραμμένη προς τον ήλιο.
3. Αφαιρέστε περίπου 2 ίντσες μεμβράνης από όλες τις άκρες του φύλλου πριν την εγκατάσταση. Αφαιρέστε όλο το φιλμ αμέσως μετά την ολοκλήρωση της κατασκευής
4. Βεβαιωθείτε ότι το θερμοκήπιο βρίσκεται σε μια επίπεδη, επίπεδη επιφάνεια.

ΓΕΝΙΚΗ ΑΣΦΑΛΕΙΑ, ΠΡΟΕΙΔΟΠΟΙΗΣΕΙΣ ΚΑΙ ΠΡΟΦΥΛΑΞΕΙΣ ΔΙΑΤΗΡΕΙΤΕ ΤΗΝ ΧΩΡΟ ΕΡΓΑΣΙΑΣ ΚΑΘΑΡΗ ΚΑΙ ΣΤΕΓΗ.

Οι ακατάστατοι, υγροί ή υγροί χώροι εργασίας προκαλούν τραυματισμούς.

ΜΕΙΝΕ ΣΕ ΕΓΡΗΓΟΡΣΗ. Προσέξτε τι κάνετε ανά πάσα στιγμή. Χρησιμοποιήστε την κοινή λογική. Μην χρησιμοποιείτε το θερμοκήπιο όταν είστε κουρασμένοι ή αποσπασμένοι από τη δουλειά που έχετε στο χέρι. Συνιστάται η χρήση γαντιών για τη συναρμολόγηση του θερμοκηπίου.

ΣΥΝΤΗΡΗΣΤΕ ΑΥΤΟ ΤΟ ΠΡΟΪΟΝ ΜΕ ΠΡΟΣΟΧΗ.

Διατηρείτε το θερμοκήπιο καθαρό και στεγνό για καλύτερη απόδοση: η συντήρηση πρέπει να γίνεται τακτικά.

ΧΡΗΣΙΜΟΠΟΙΗΣΤΕ ΤΟ ΚΑΤΑΛΛΗΛΟ ΠΡΟΪΟΝ ΓΙΑ ΤΗ ΔΟΥΛΕΙΑ.

Μην επιχειρήσετε να αναγκάσετε ένα μικρό προϊόν να κάνει τη δουλειά ενός μεγαλύτερου βιομηχανικού προϊόντος.

Υπάρχουν ορισμένες εφαρμογές για τις οποίες σχεδιάστηκε το θερμοκήπιο. Θα κάνει τη δουλειά καλύτερα και με μεγαλύτερη ασφάλεια με τον τρόπο για τον οποίο προοριζόταν. Μην τροποποιείτε το θερμοκήπιο και μην χρησιμοποιείτε το θερμοκήπιο για σκοπό για τον οποίο δεν προοριζόταν.

ΔΙΑΤΗΡΗΣΤΕ ΕΝΑ ΑΣΦΑΛΕΣ ΕΡΓΑΣΙΑΚΟ ΠΕΡΙΒΑΛΛΟΝ.

Κρατήστε τον χώρο εργασίας τακτοποιημένο. Βεβαιωθείτε ότι υπάρχει επαρκές περιβάλλον

χώρο εργασίας. Αποφύγετε περιοχές υψηλής κυκλοφορίας.

Διατηρείτε πάντα την περιοχή εργασίας απαλλαγμένη από εμπόδια, λίπη, λάδια, σκουπίδια και άλλα υπολείμματα.

ΣΩΣΤΗ ΤΟΠΟΘΕΣΙΑ ΘΕΡΜΟΚΗΠΙΟΥ.

Βεβαιωθείτε ότι το θερμοκήπιο βρίσκεται σε μια επίπεδη, επίπεδη επιφάνεια.

Πίσω

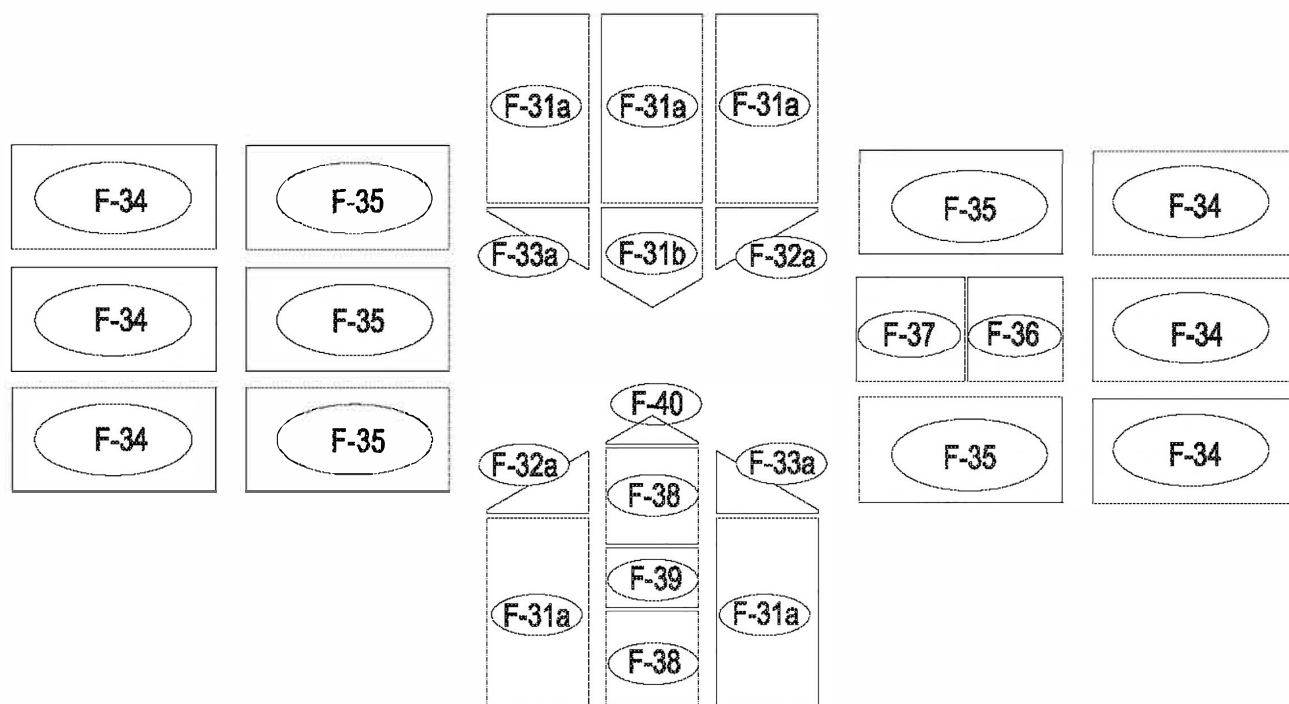

Εμπρός



Λευκή μεμβράνη οπάλιο

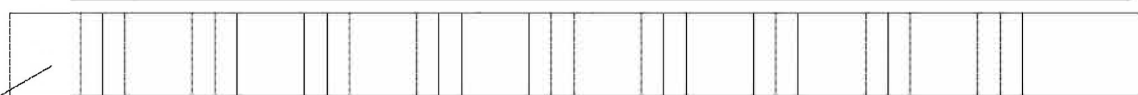







Φύλλο Η/Υ

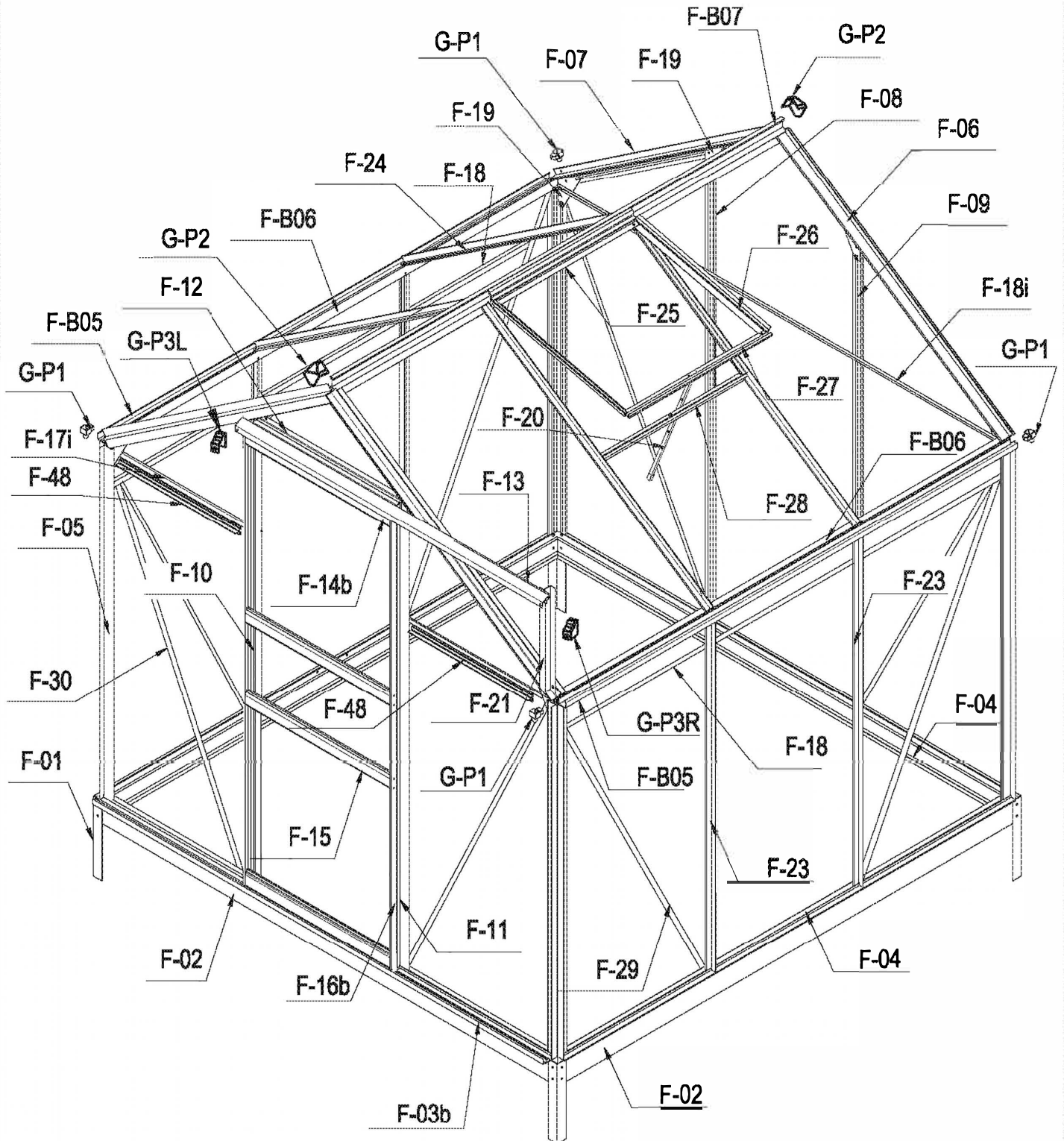









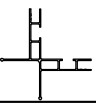





διαφανές φιλμ







Οι δύο πλευρές του φύλλου PC καλύπτονται με λεπτή μεμβράνη. Η μεμβράνη της μίας είναι διαφανής, η άλλη μεμβράνη είναι λευκό οπάλιο. Η προστατευμένη από την υπεριώδη ακτινοβολία πλευρά του φύλλου καλύπτεται με λευκό φιλμ οπάλιο και πρέπει να κοιτάζει προς τον ήλιο.







6X6FT



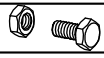

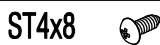









BASE			
IMAGE	NO.	L.	QTY
	F-01	280	4
	F-02	1882	4
	F-03b	1833	1
	F-04	1833	3
	F-B13		16

WALL AND ROOF			
IMAGE	NO.	L.	QTY
	F-05	1240	4
	F-06	1105	2
	F-07	1105	2
	F-08	1650	1
	F-09	1650	1
	F-23	1240	4
	F-24	1100	4
	F-48	568	5
	F-10	1644	1
	F-11	1644	1
	F-B05	1836	2
	F-B06	1833	2
	F-17i	618	2
	F-18i	1815	1
	F-18	1815	2
	F-29	1360	4
	F-30	1328	4
	F-B07	1833	1
	F-31a	1217x585	5
	F-31b	618x585	1
	F-32a	412x585	2
	F-33a	412x585	2
	F-34	1238x585	6
	F-35	1110x585	5
	F-36	540x585	1
	F-40		1
	F-19		8



WINDOW			
IMAGE	NO.	L.	QTY
	F-20	360	1
	F-25	580	1
	F-26	550	2
	F-27	580	1
	F-28	620	1
	F-37	577x583	1

SCREW			
IMAGE	NO.	L.	QTY
	F-B14		140
	F-B15a		12
	F-B16		6
	F-18		95
	F-17		73
	F-17a		22

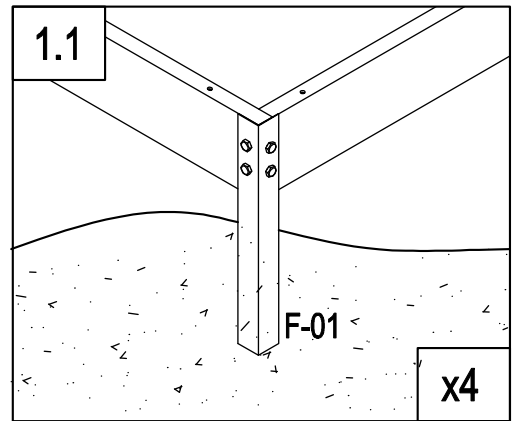
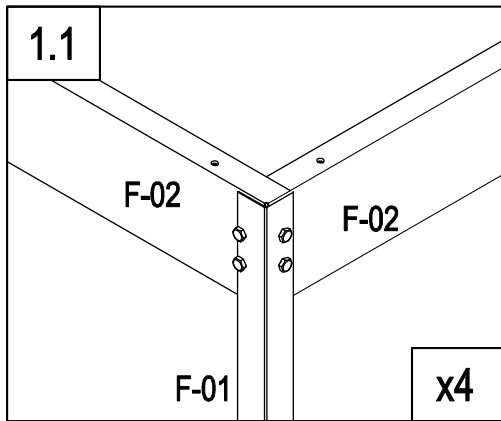
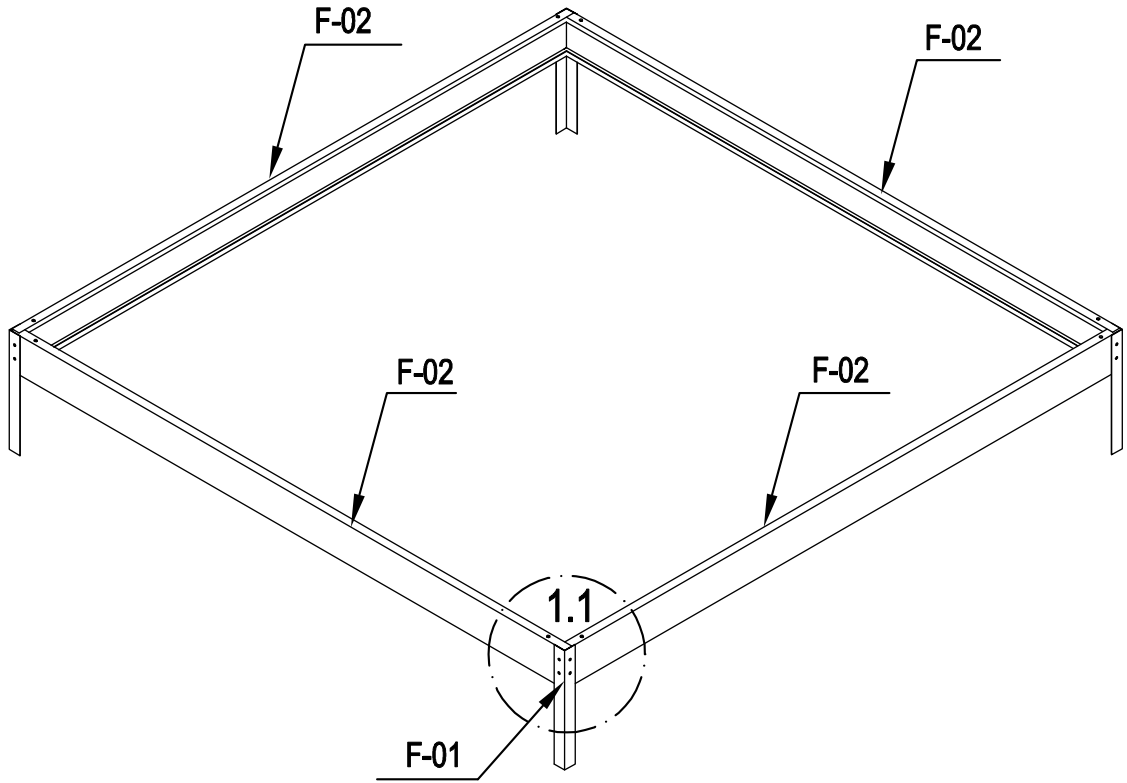

DOOR			
IMAGE	NO.	L.	QTY
	F-12	572.5	1
	F-13	1240	1
	F-14b	600	2
	F-15	600	2
	F-16b	1615	2
	F-21	376	1
	F-22b		4
	F-38	590x598	2
	F-39	251x598	1

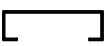
PLASTIC			
IMAGE	NO.	L.	QTY
	G-P1		4
	G-P2		2
	G-P3L		1
	G-P3R		1



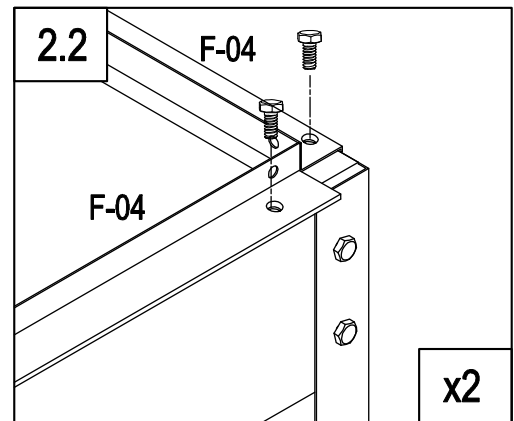
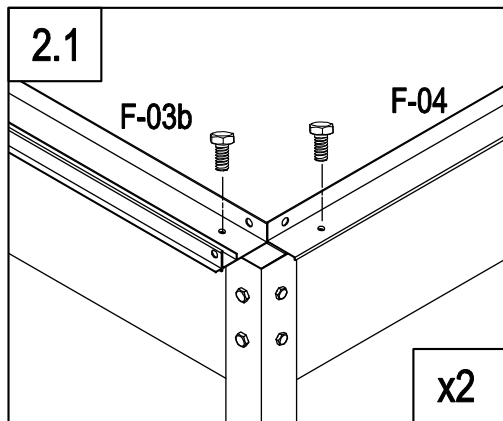
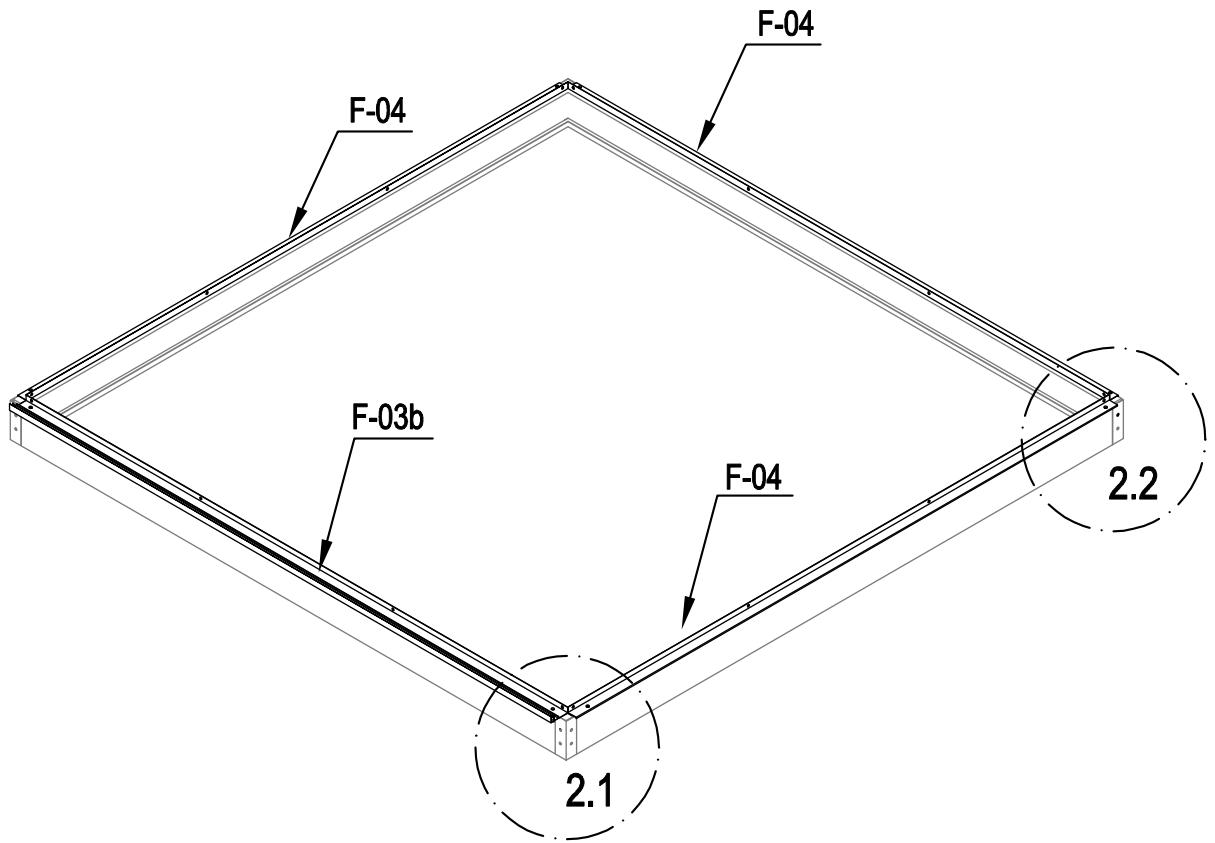

	F-02	4
	F-01	4
	F-B14	16



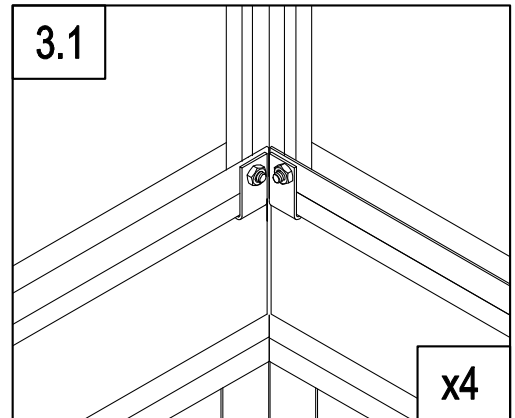
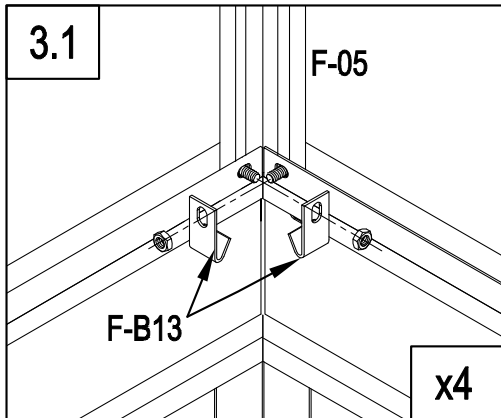
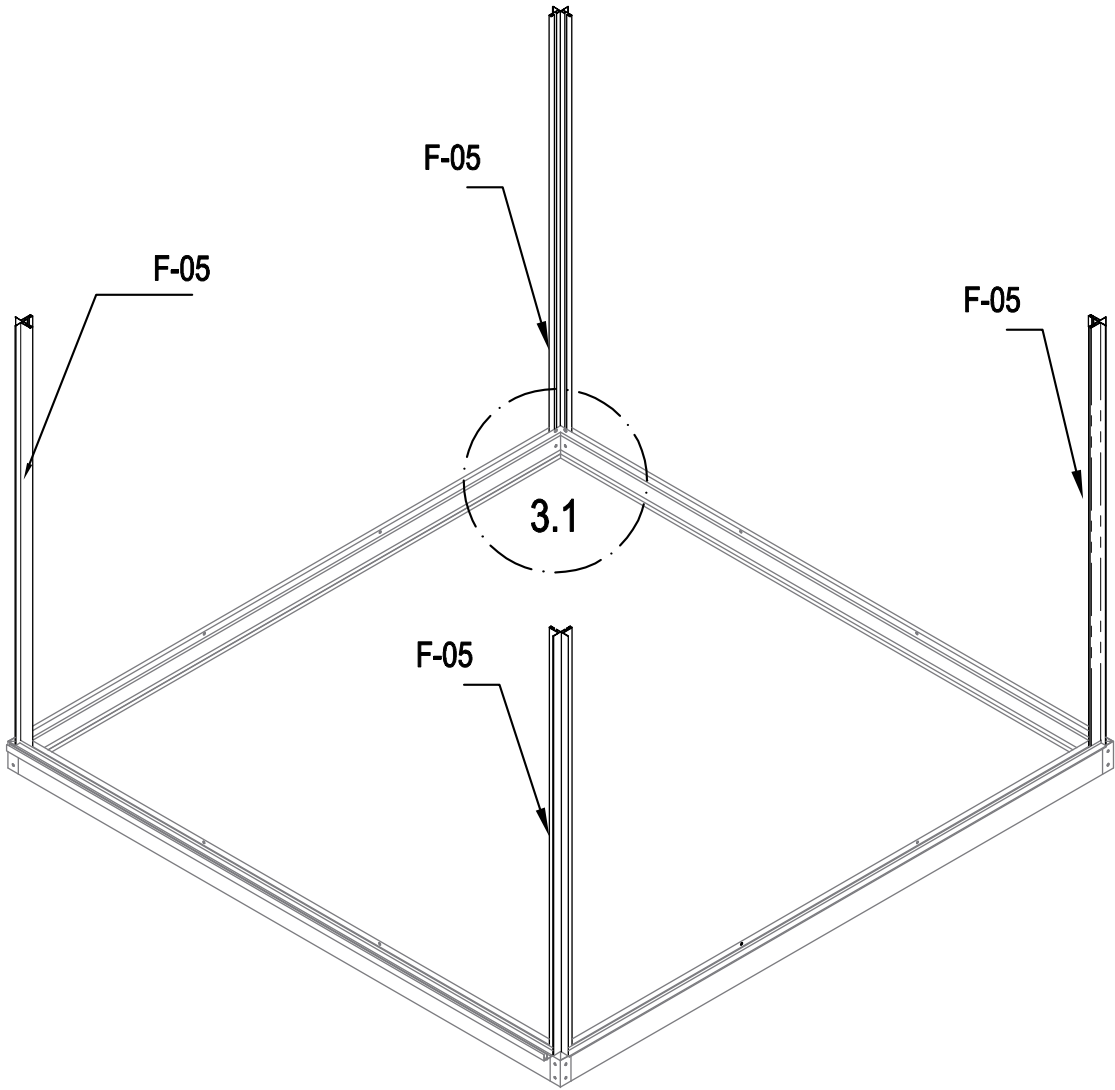

	F-04	3
	F-03b	1
	F-B14	8

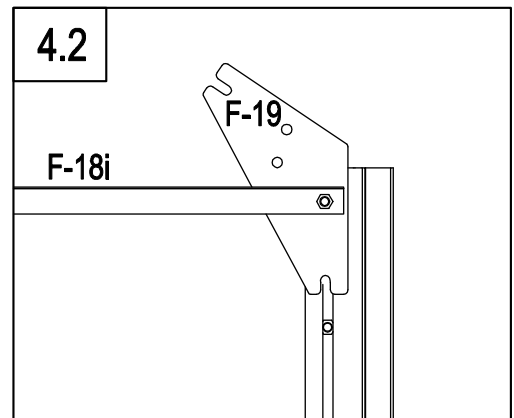
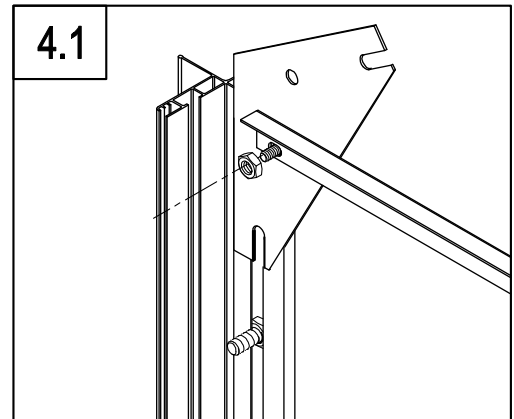
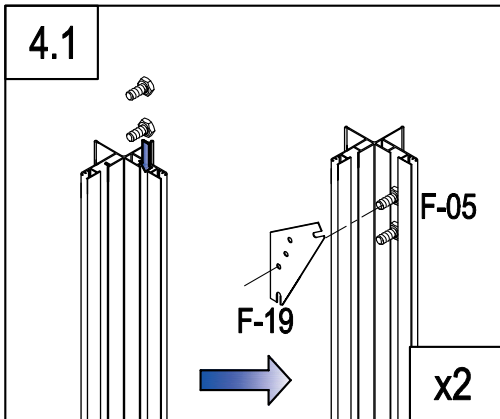
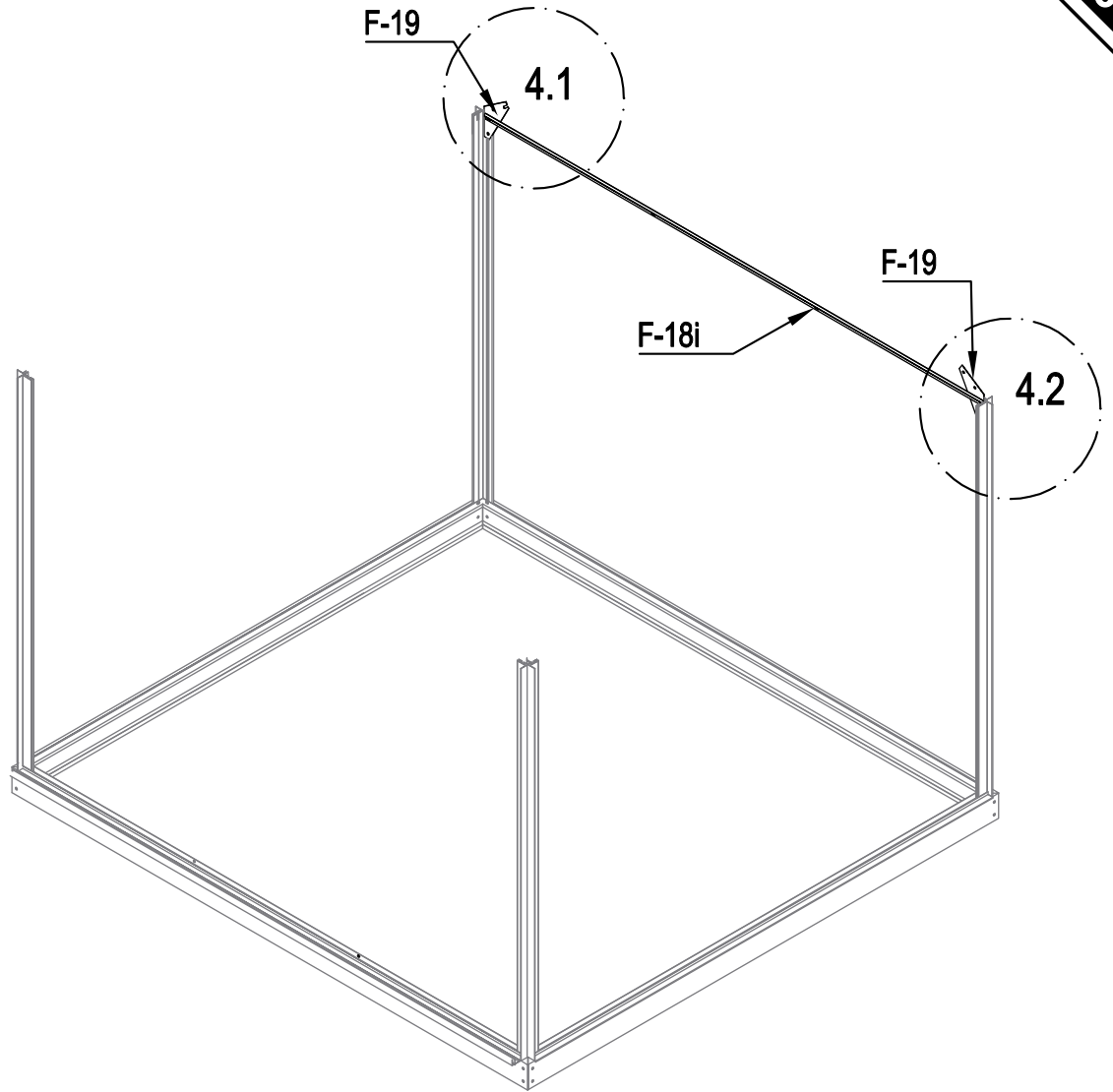

	F-05	4
	F-B13	8
	F-B14	8

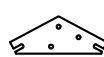

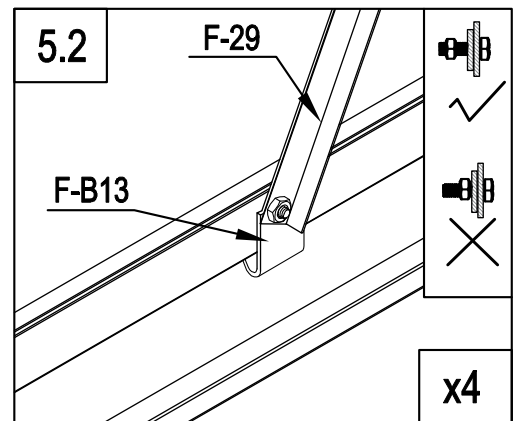
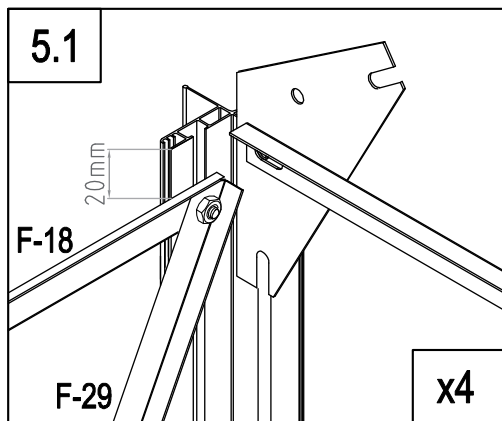
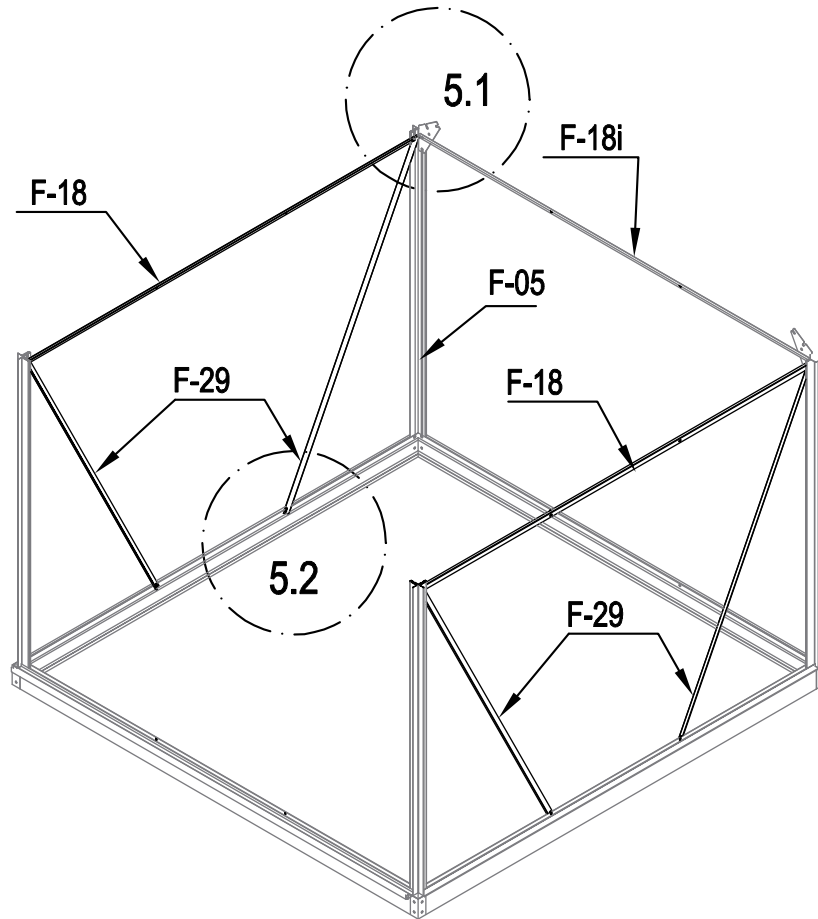

	F-18i	1
	F-19	2
	F-B14	4

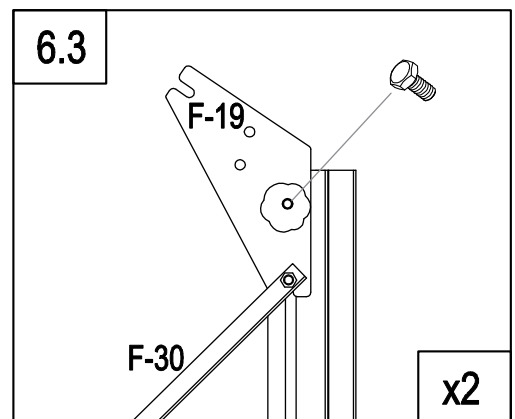
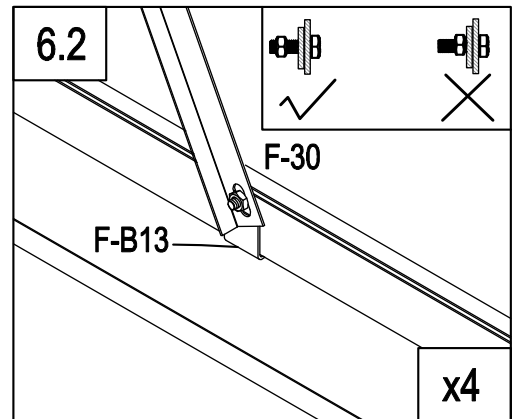
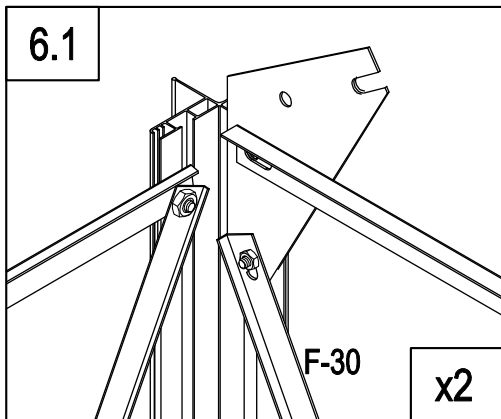
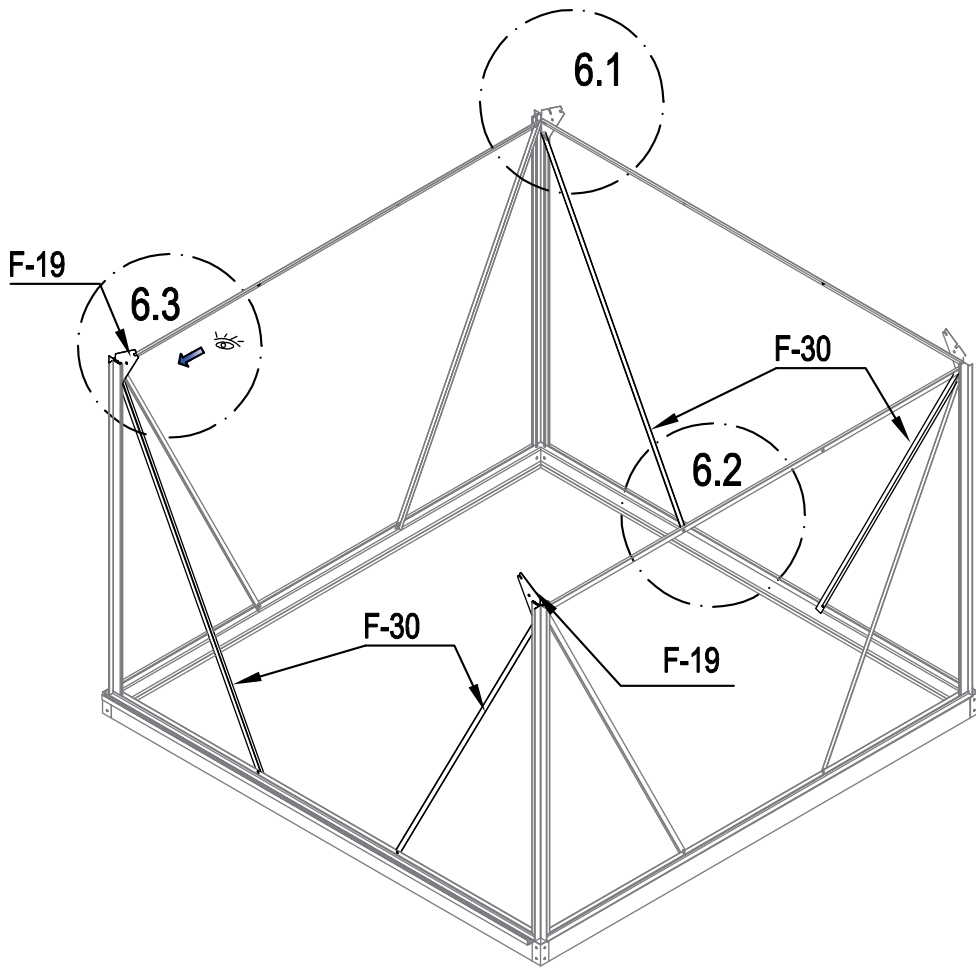

	F-B13	4
	F-29	4
	F-18	2
	F-B14	8

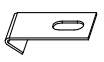

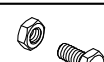

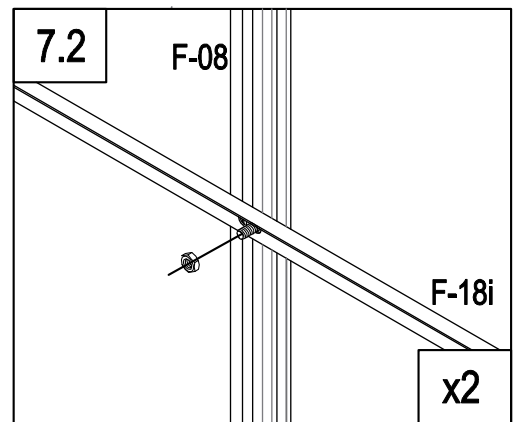
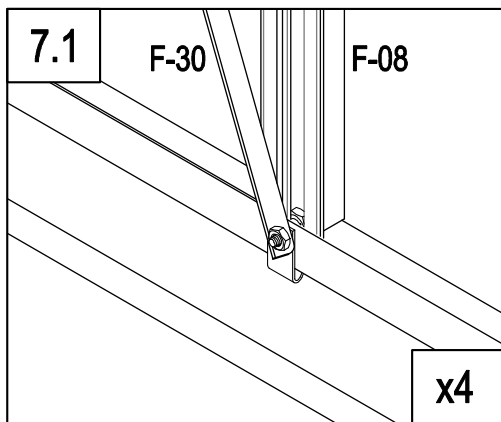
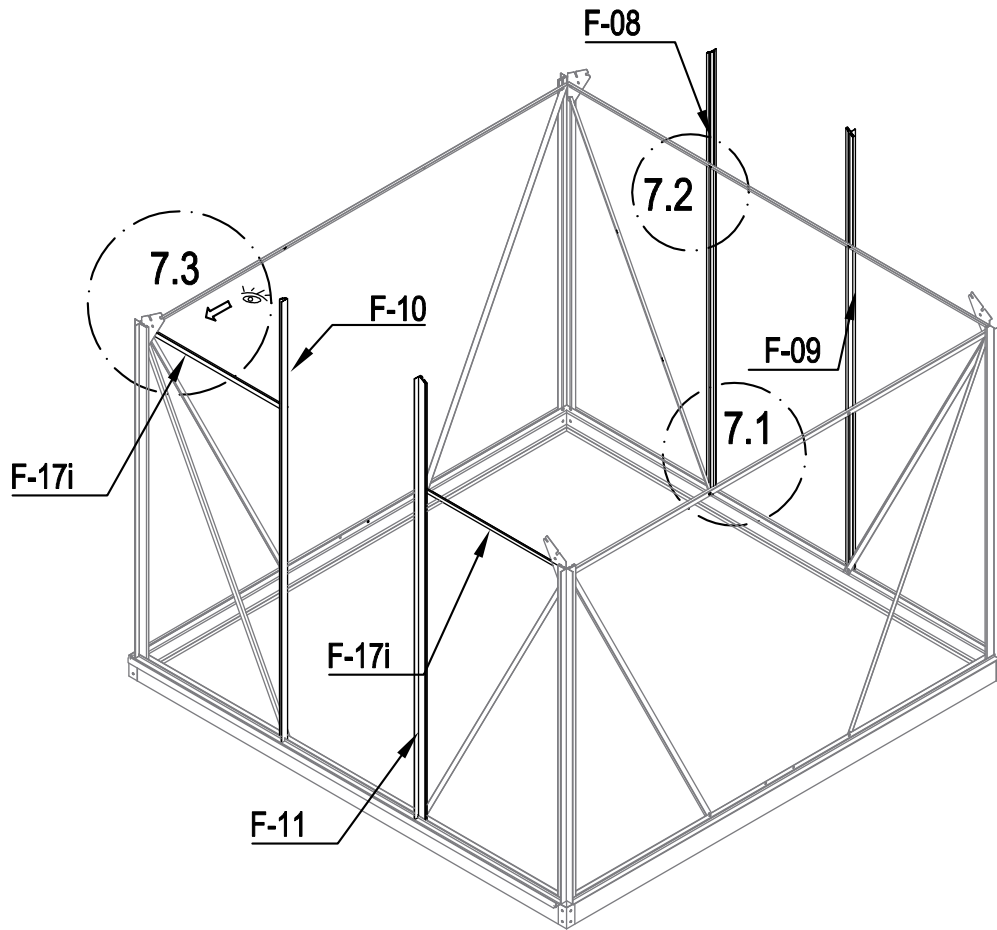
	F-B13	4
	F-30	4
	F-19	2
	F-B14	8



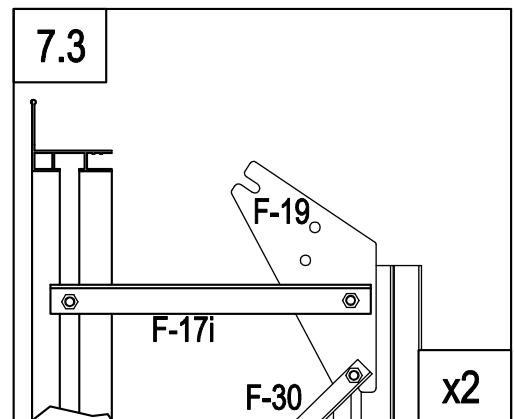

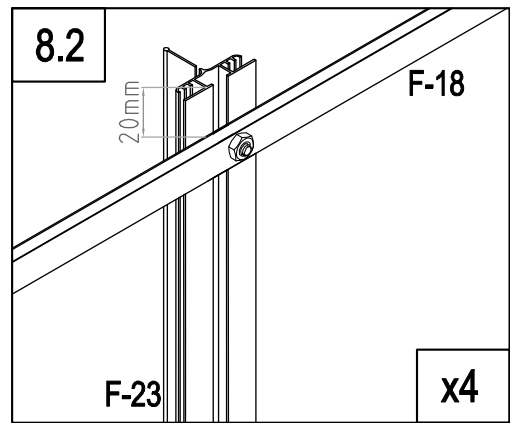
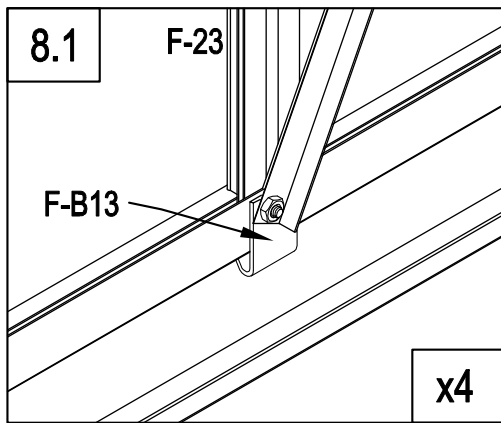
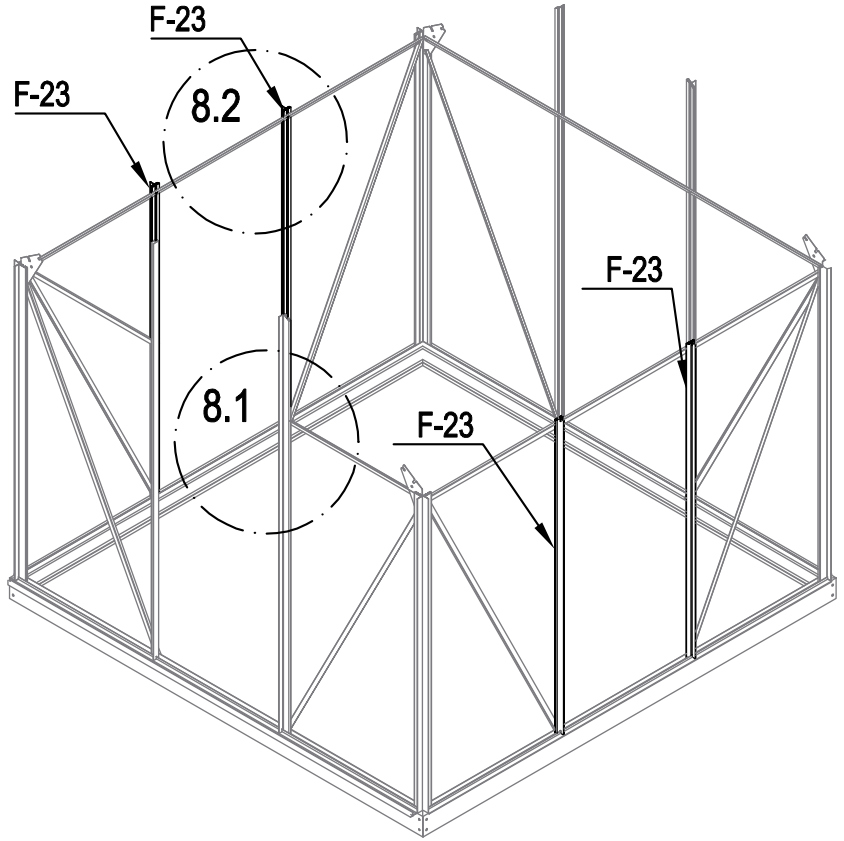
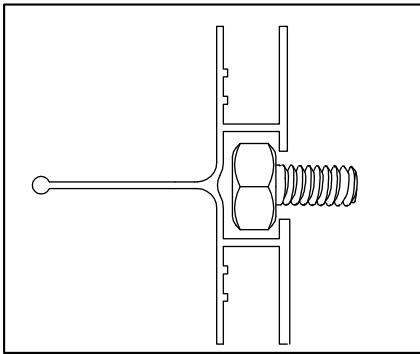
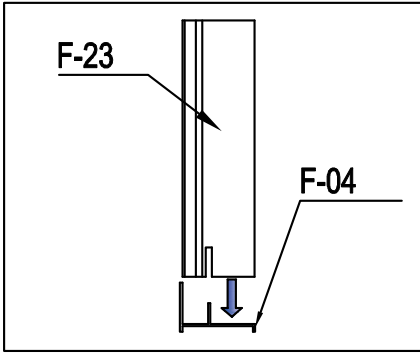
	F-08	1
	F-09	1
	F-10	1
	F-11	1
	F-17i	2
	F-B14	4





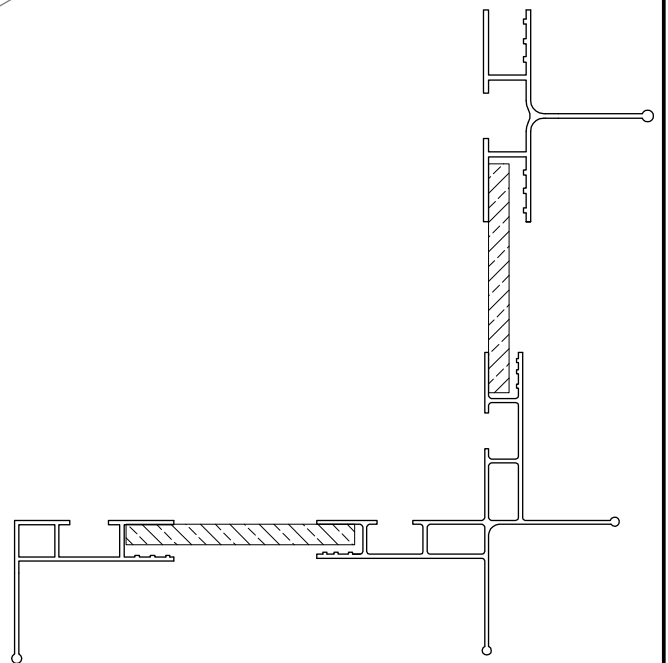
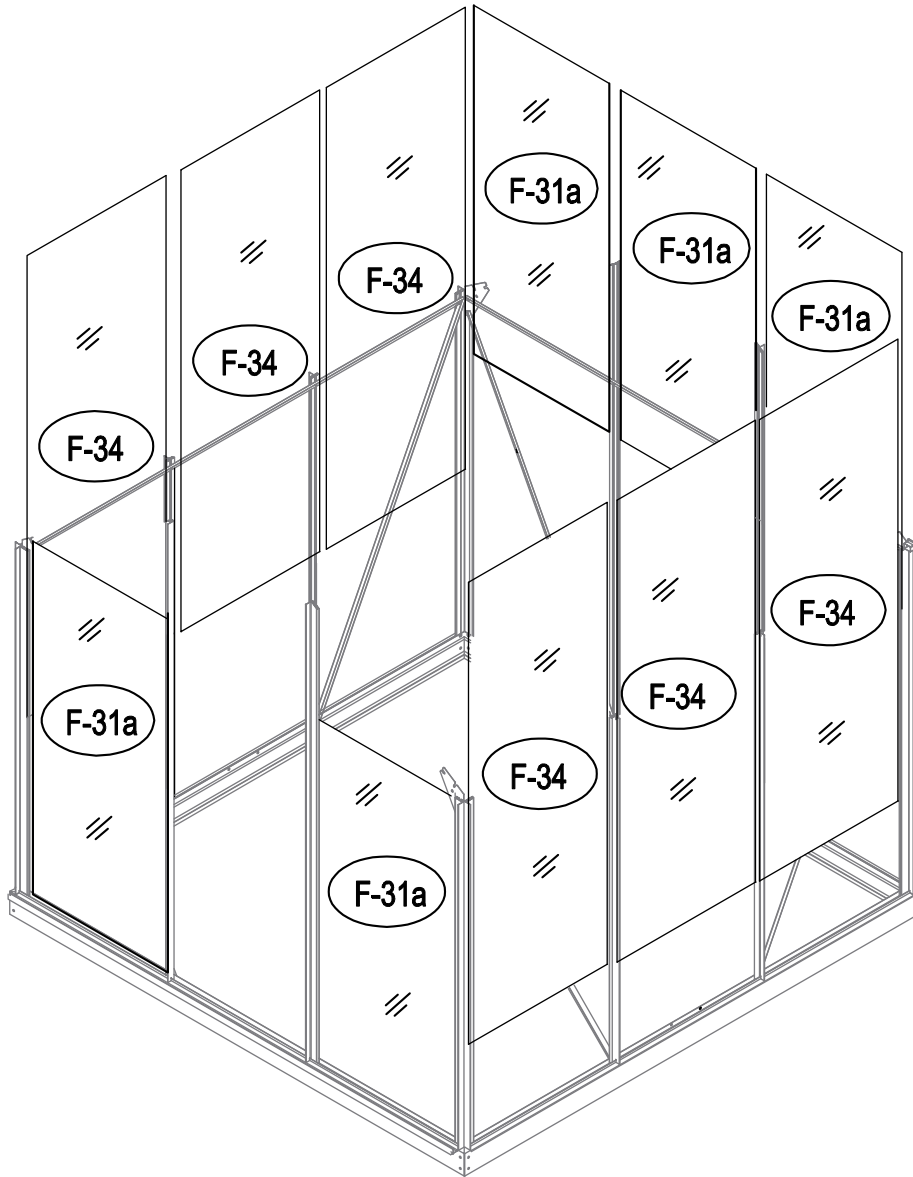



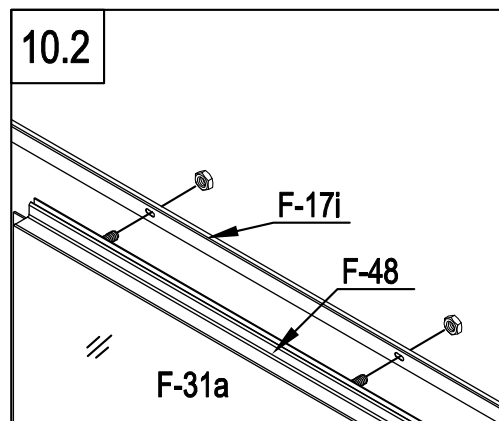
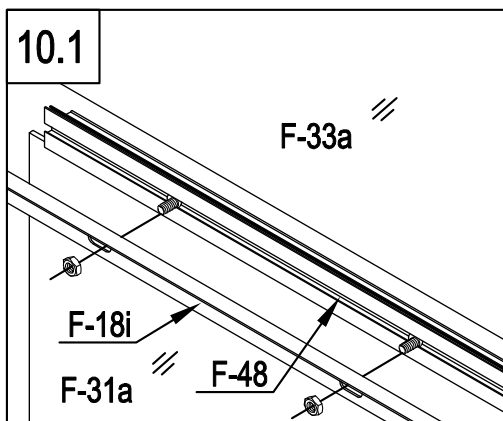
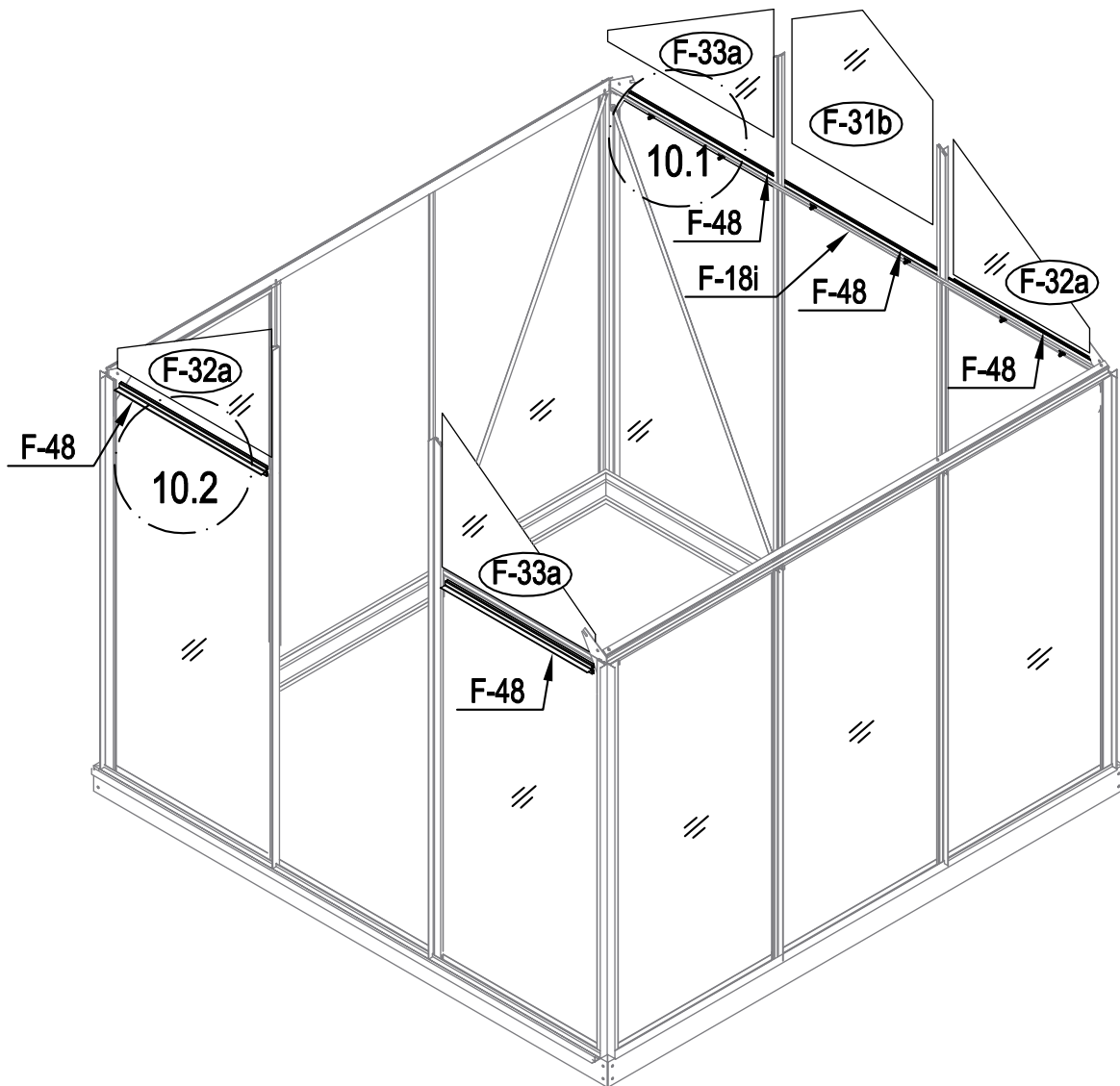

	F-23	4
	F-B14	4





	F-31a	5
	F-34	6

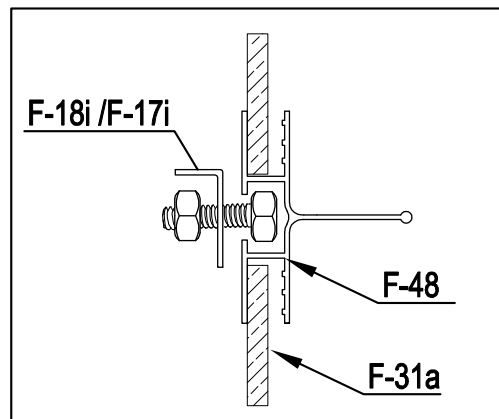

	F-31b	1
	F-32a	2
	F-33a	2
	F-48	5
	F-B14	10

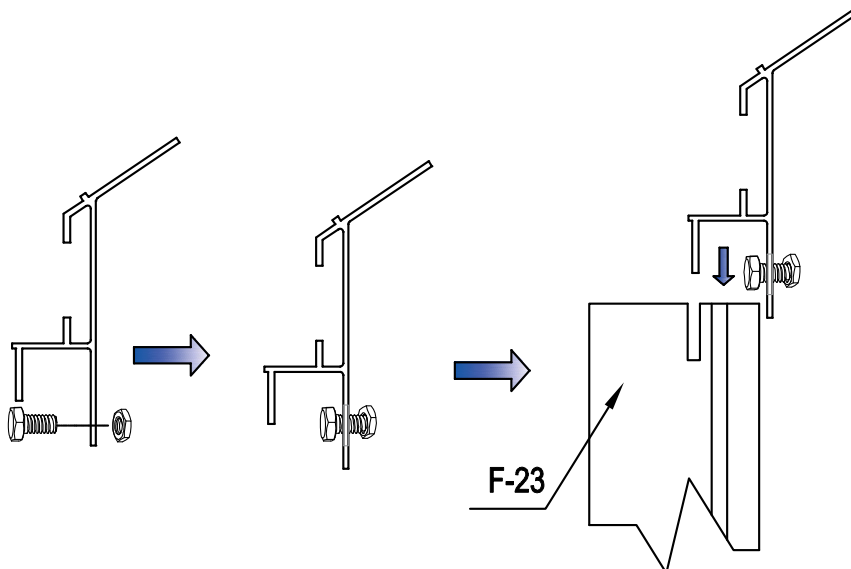
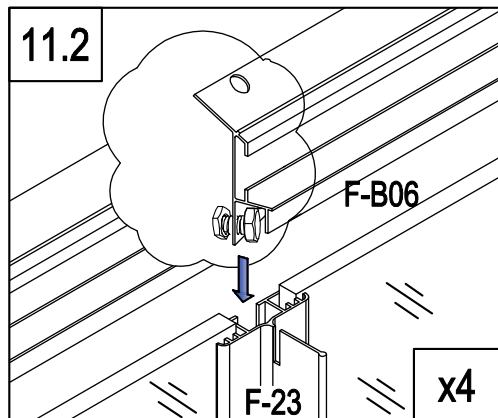
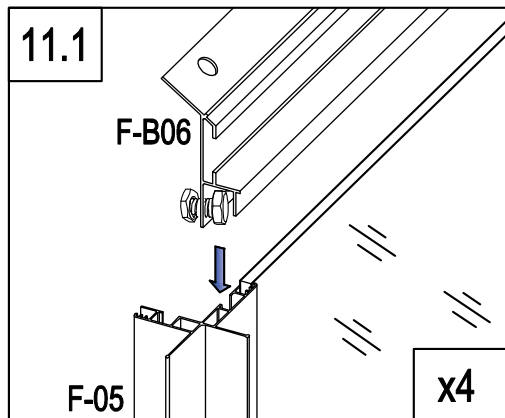
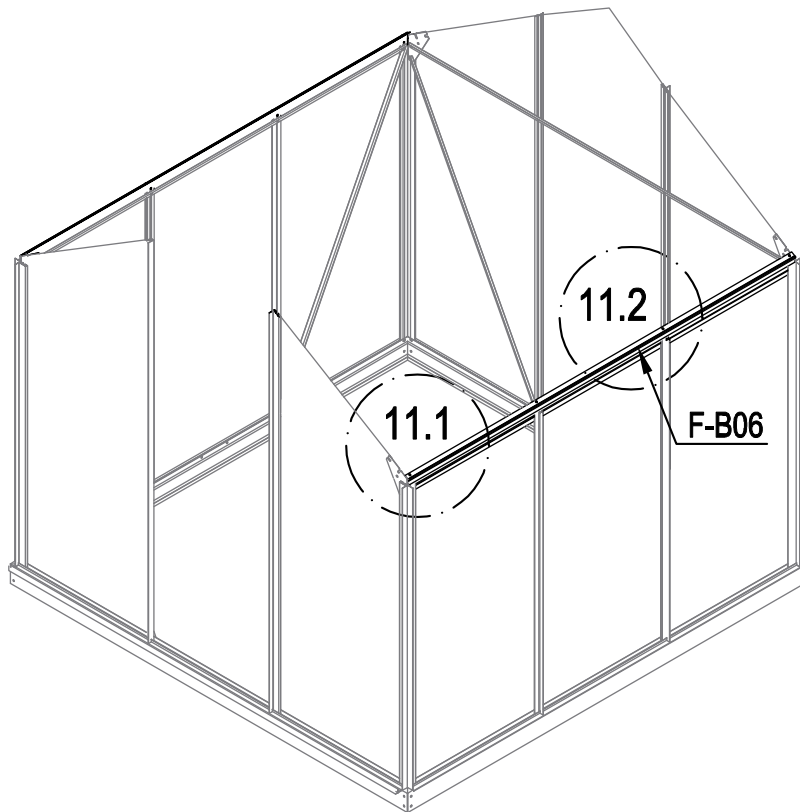

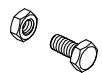

	F-B06	2
	F-B14	8

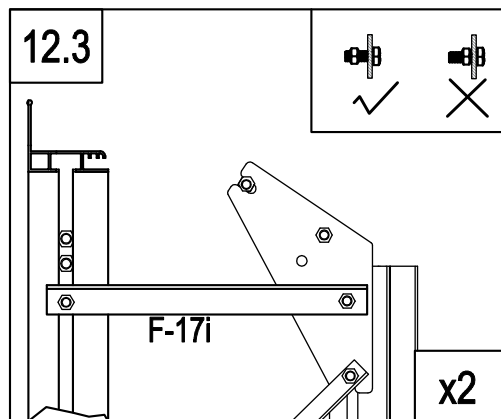
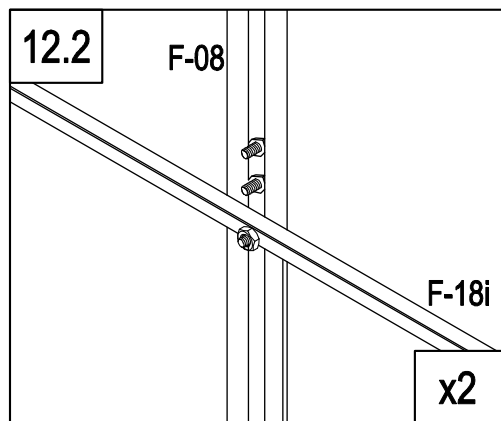
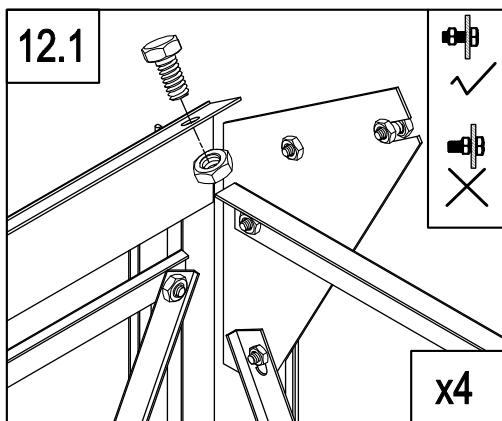
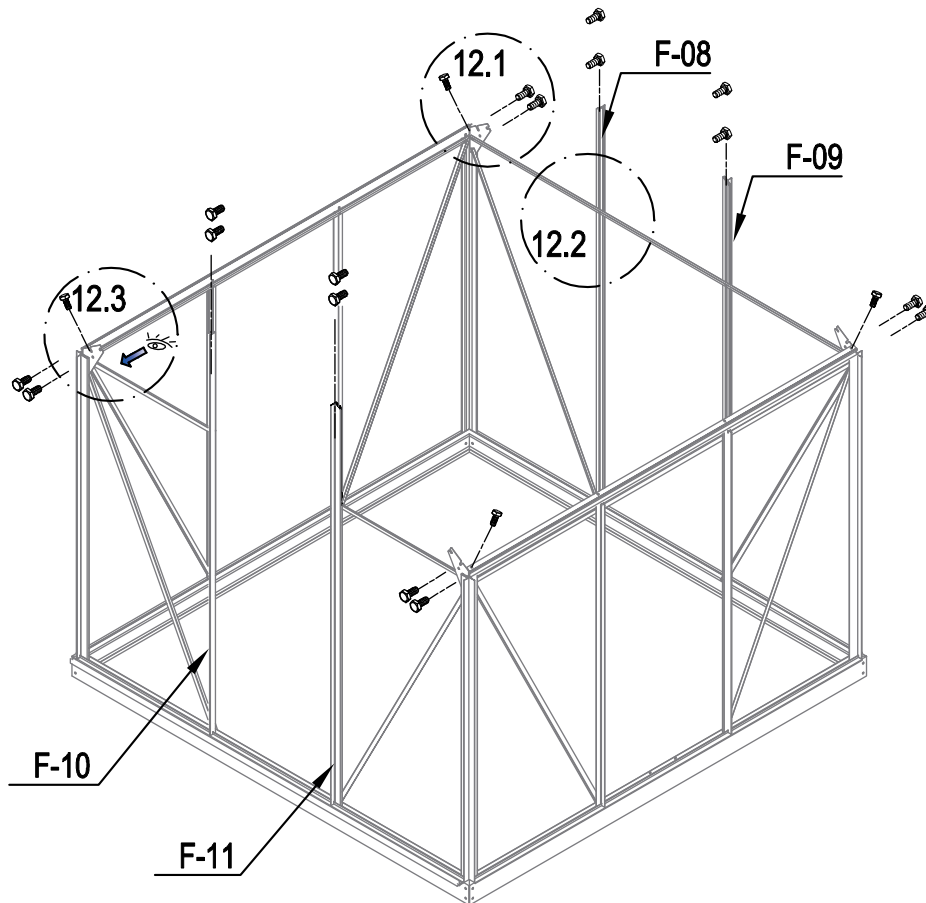

	<p>F-B14</p>	<p>20</p>
--	--------------	-----------

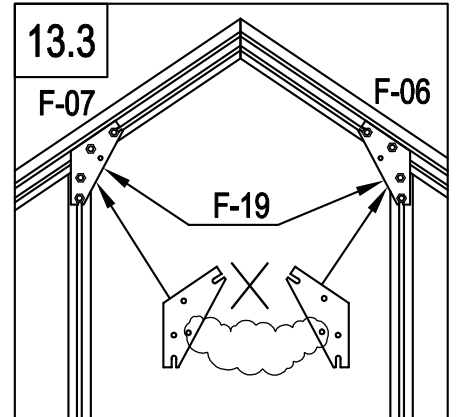
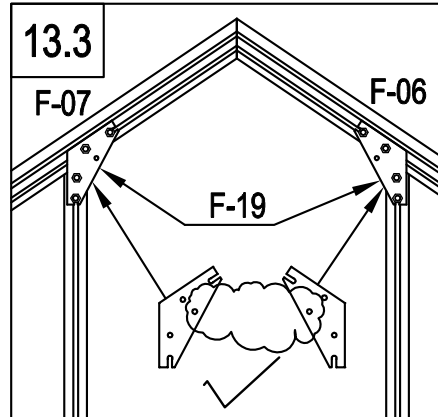
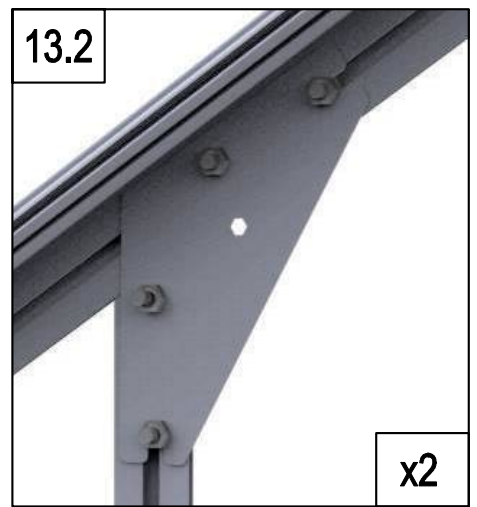
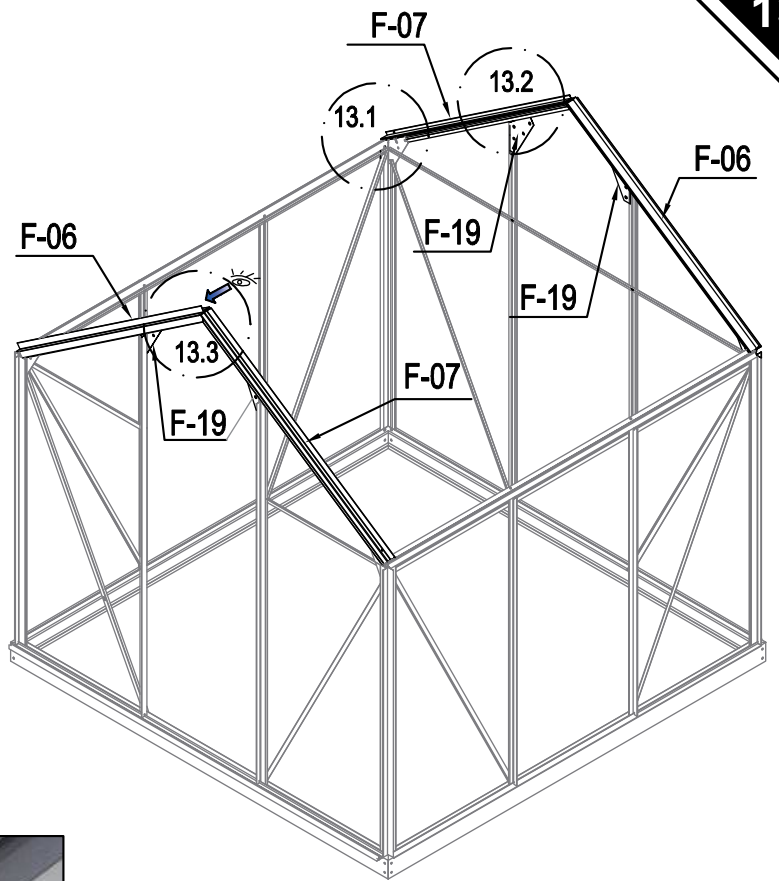
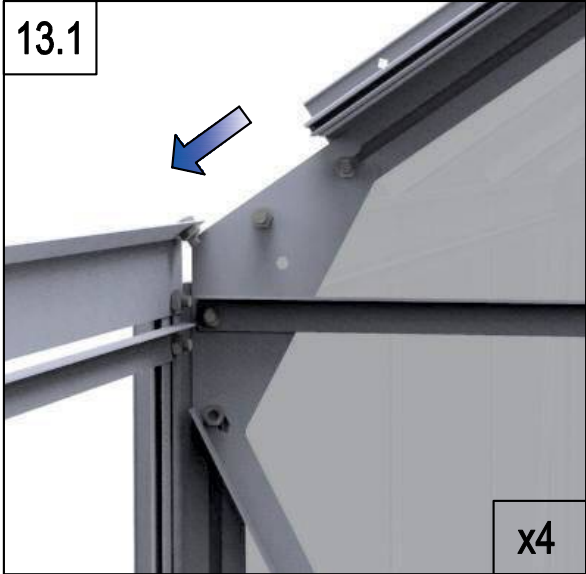

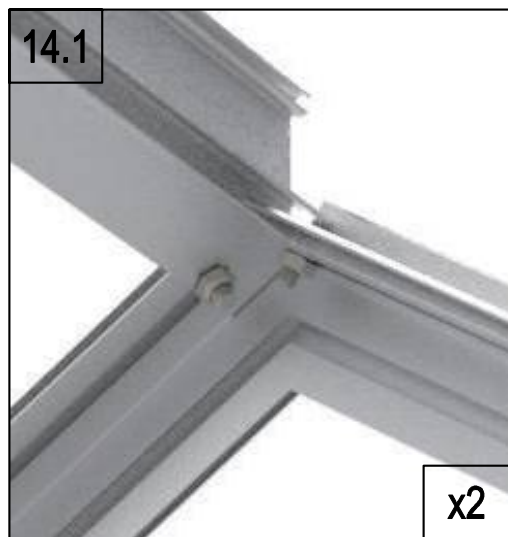
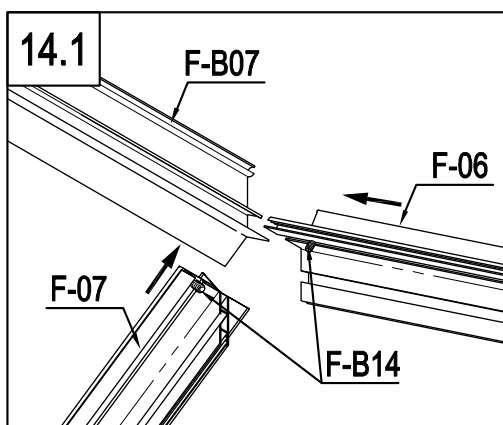
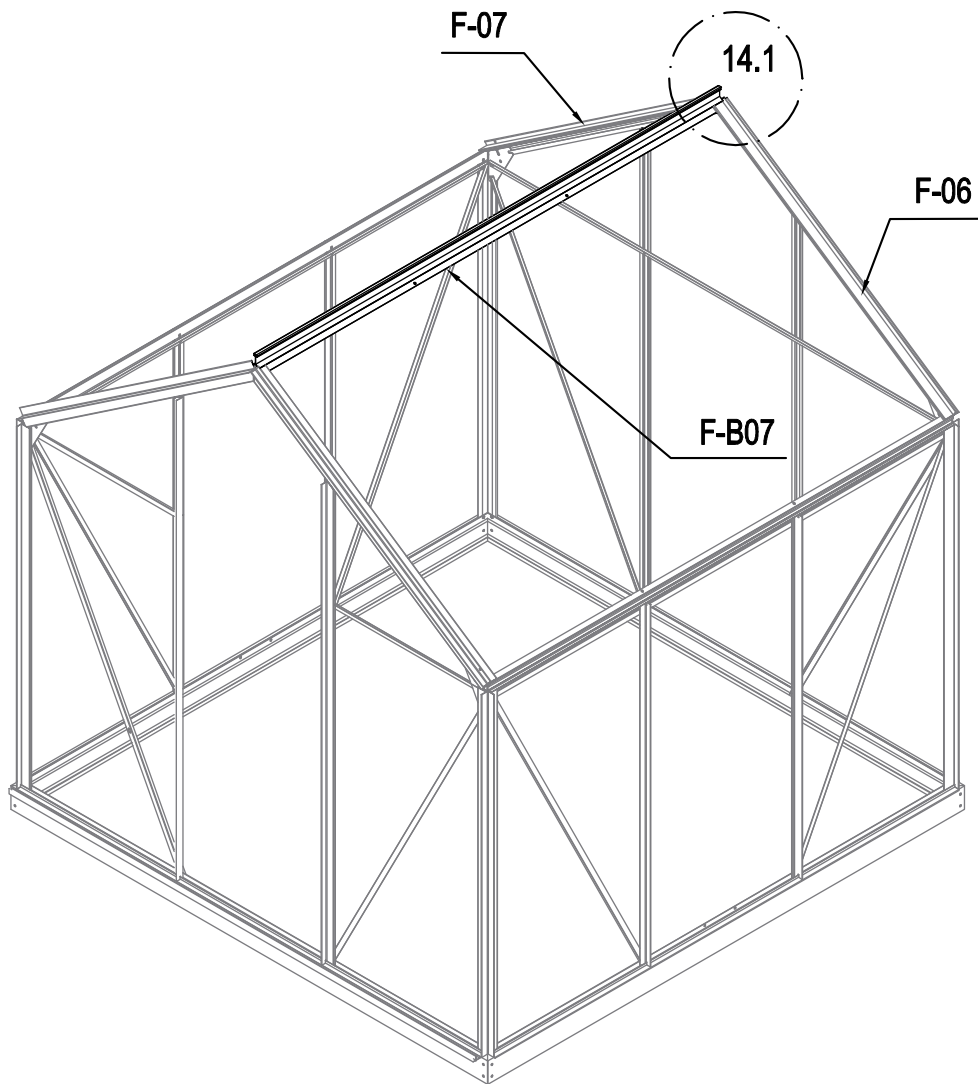

	F-06	2
	F-07	2
	F-19	4
	F-B14	8

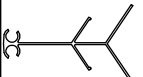
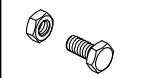

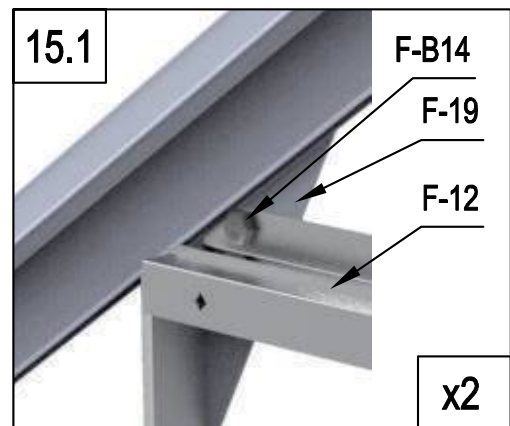
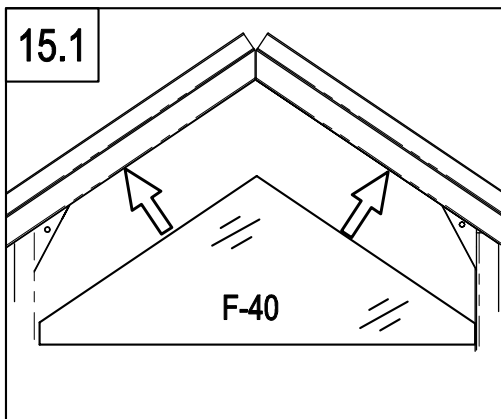
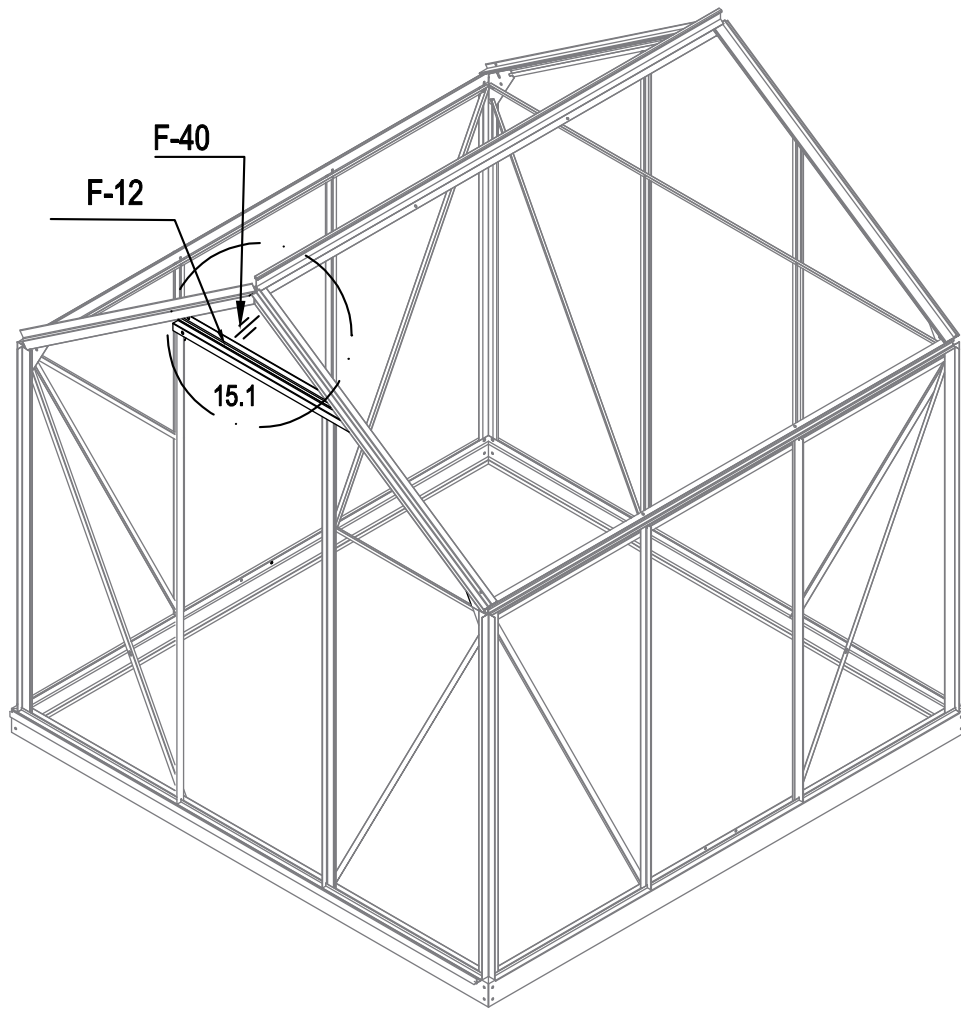
	F-B07	1
	F-B14	4



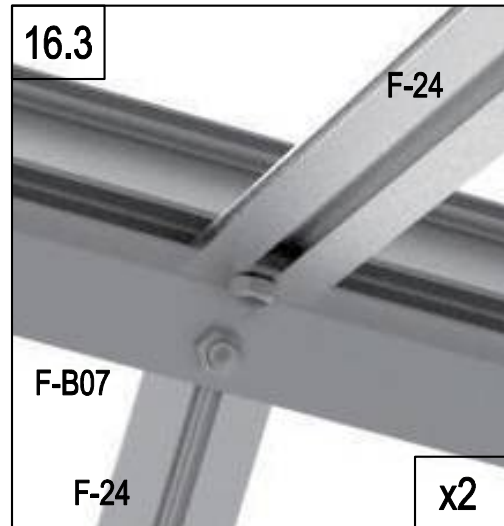
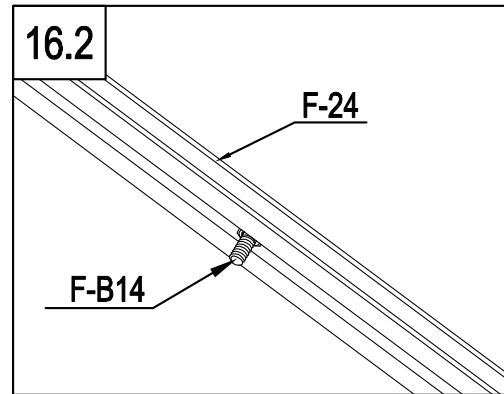
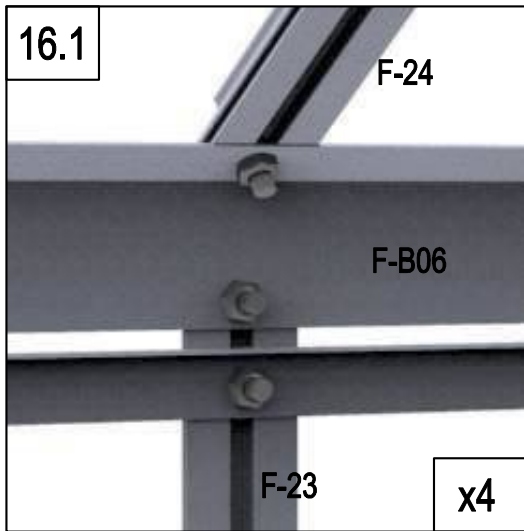
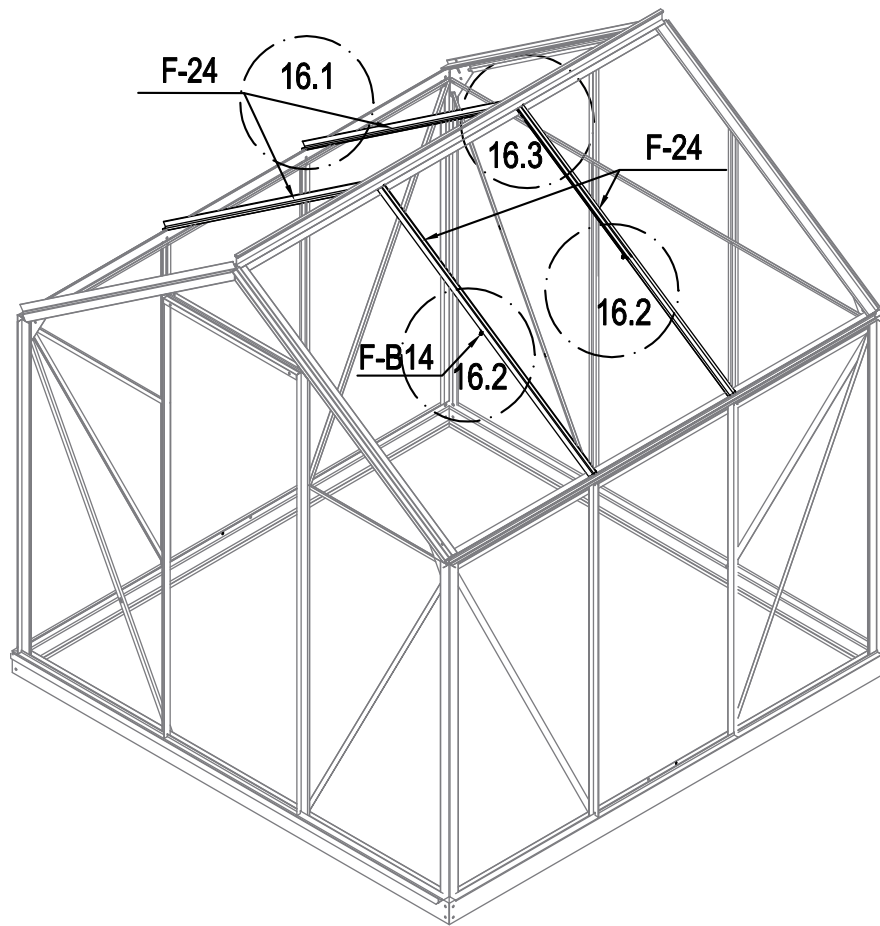

	F-12	1
	F-40	1
	F-B14	2

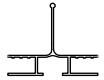
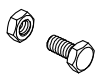

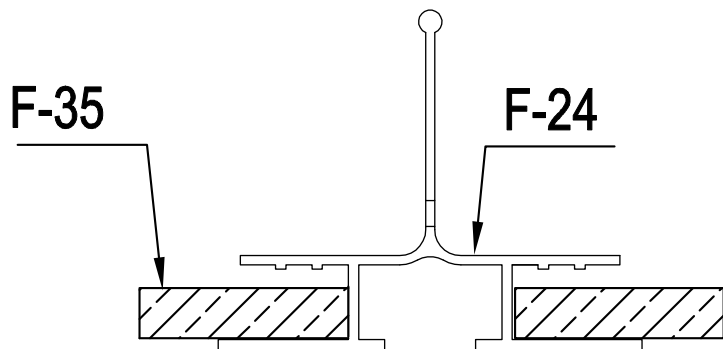
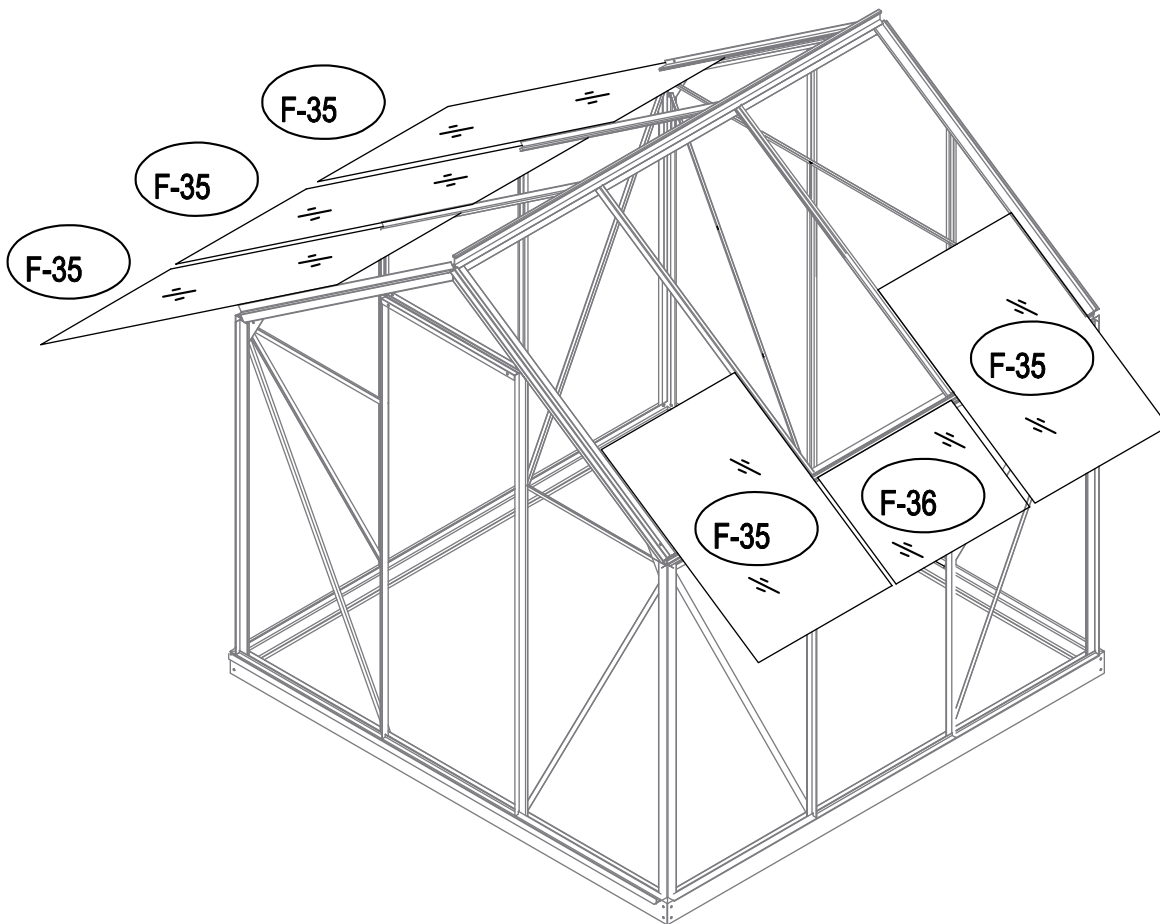

	F-24	4
	F-B14	10



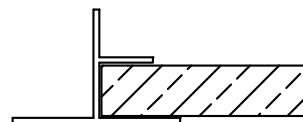
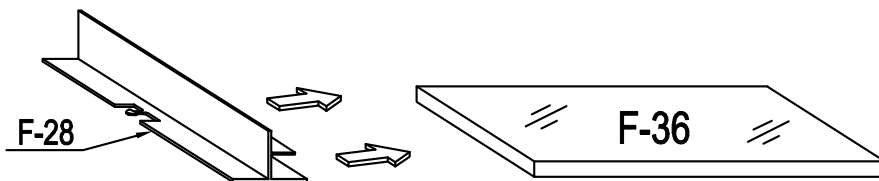
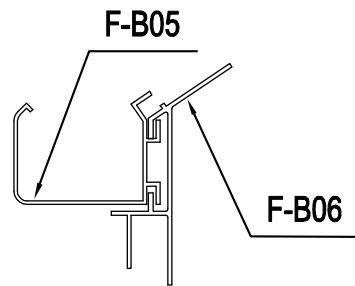
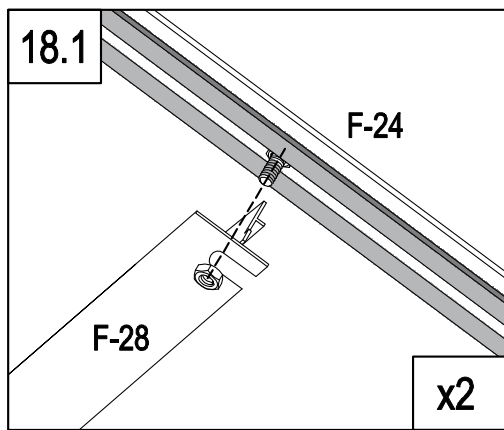
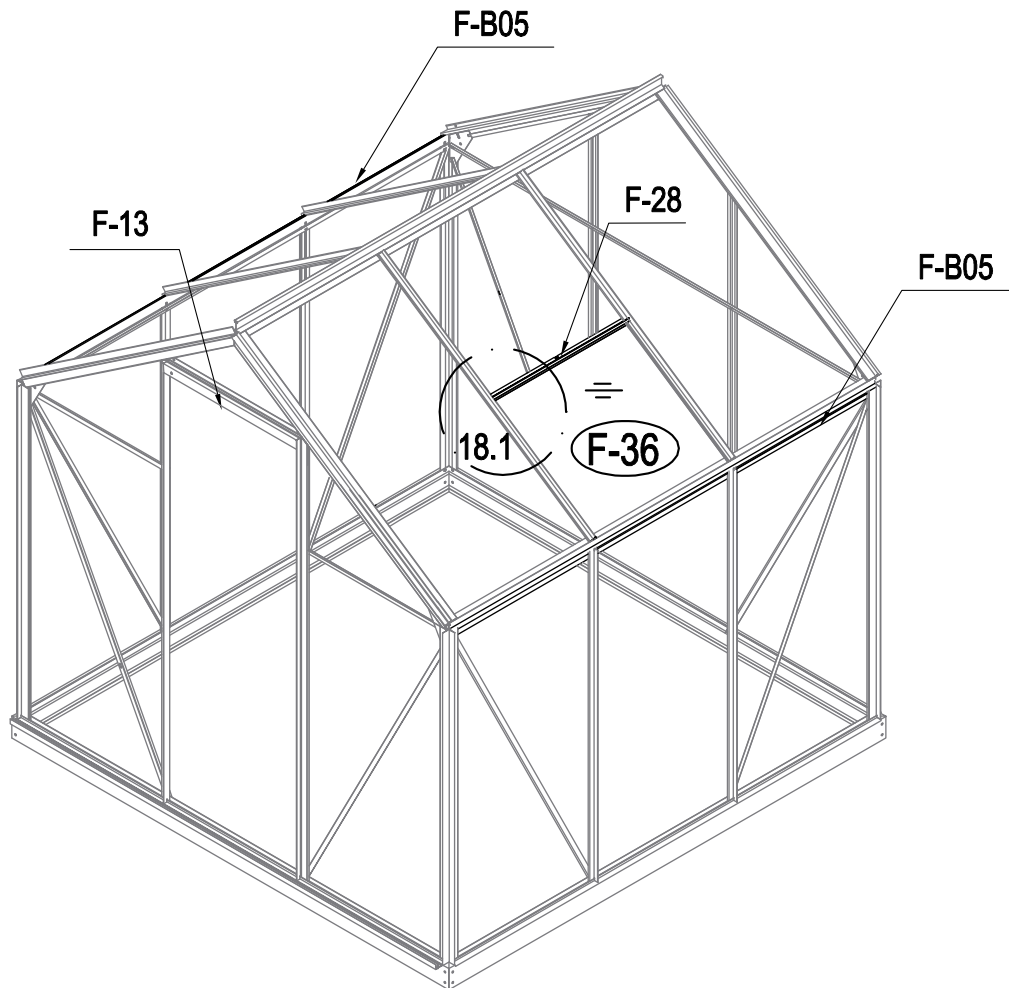

	F-36	1
	F-35	5

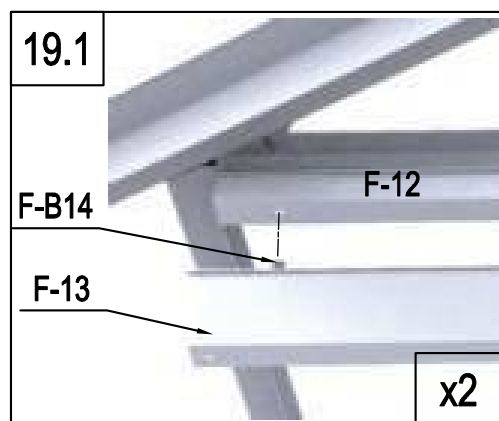
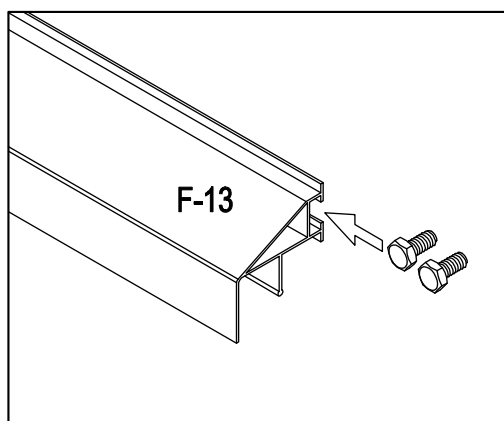
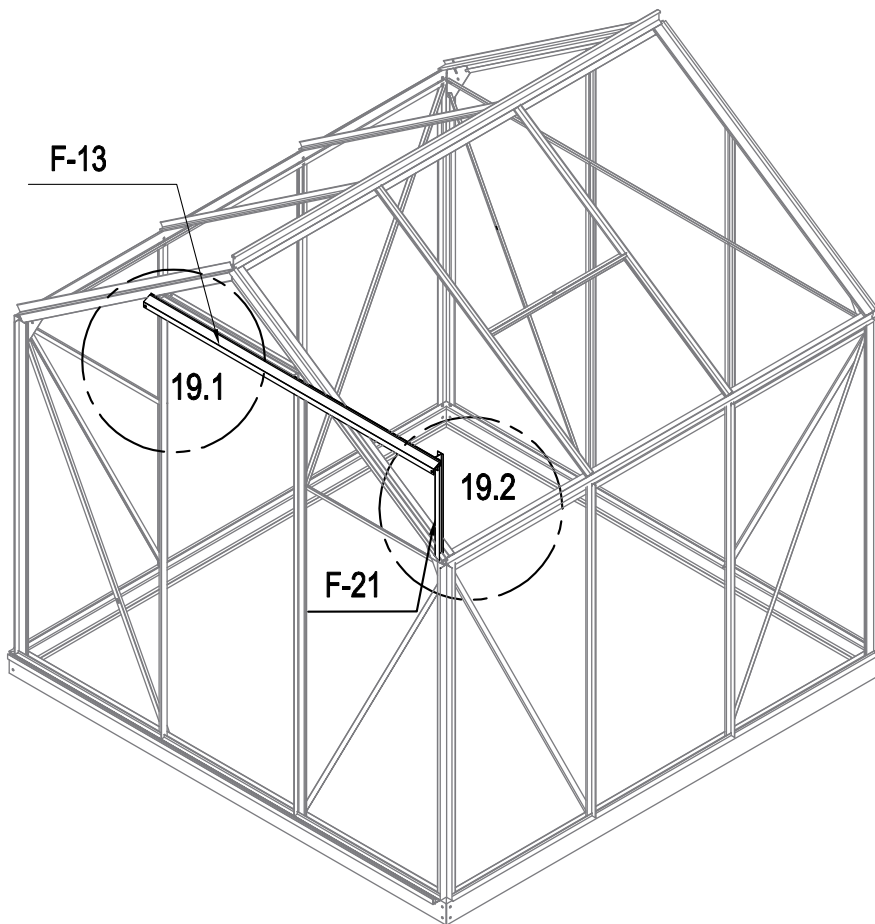

	F-B05	2
	F-28	1



	F-13	1
	F-21	1
	F-B14	4

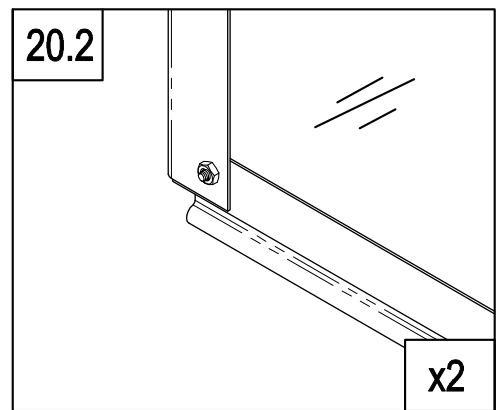
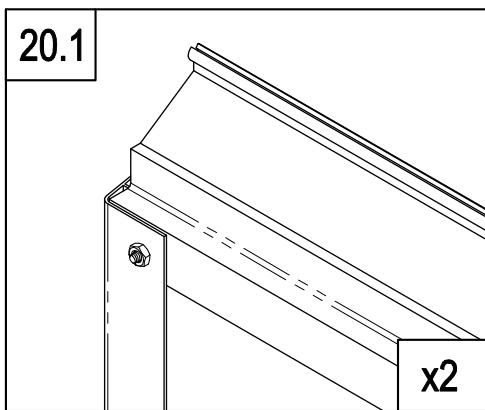
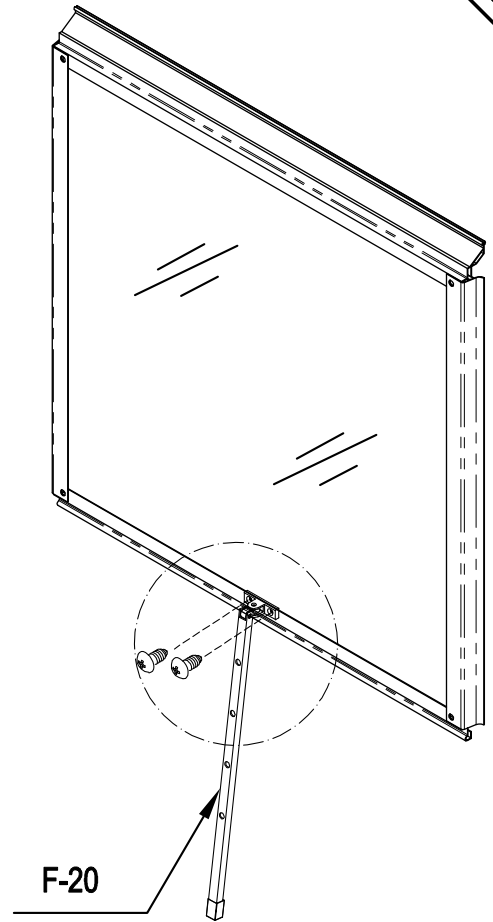
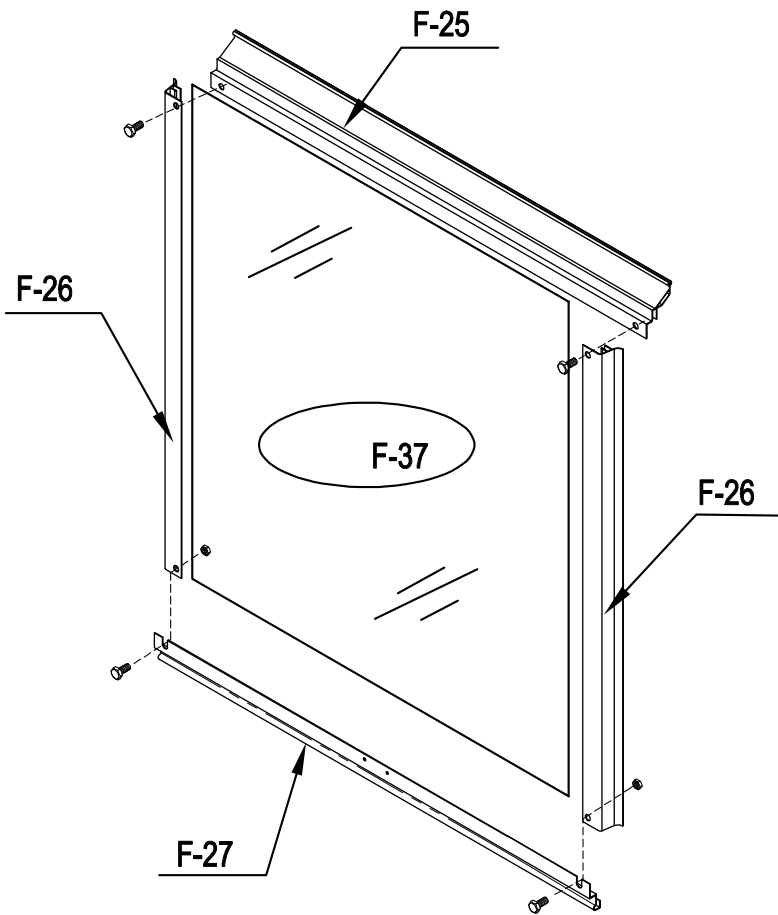

	F-25	1
	F-26	2
	F-27	1
	F-20	1
	F-37	1
	F-B16	2
	F-B14	4

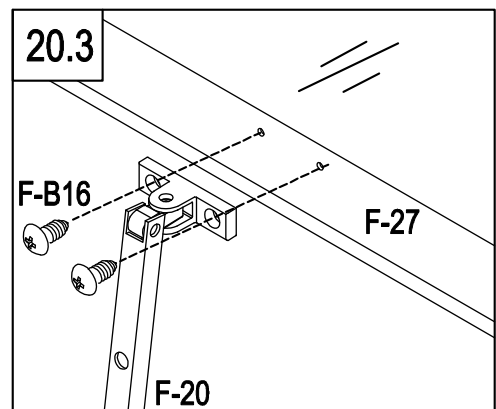

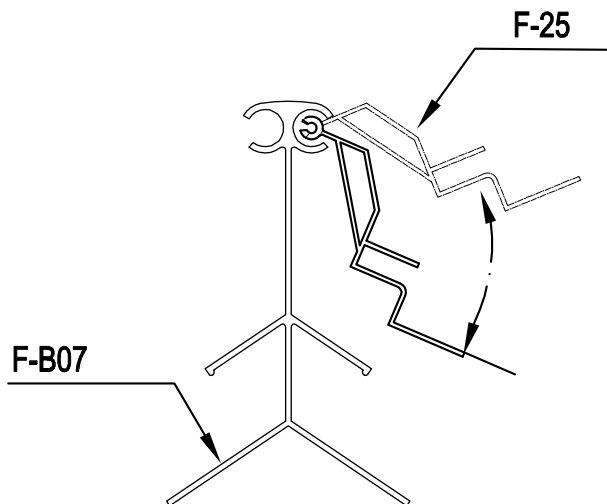
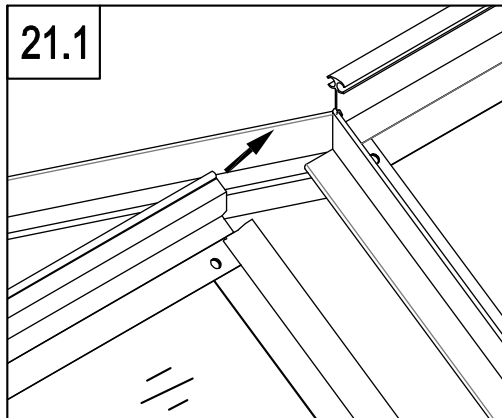
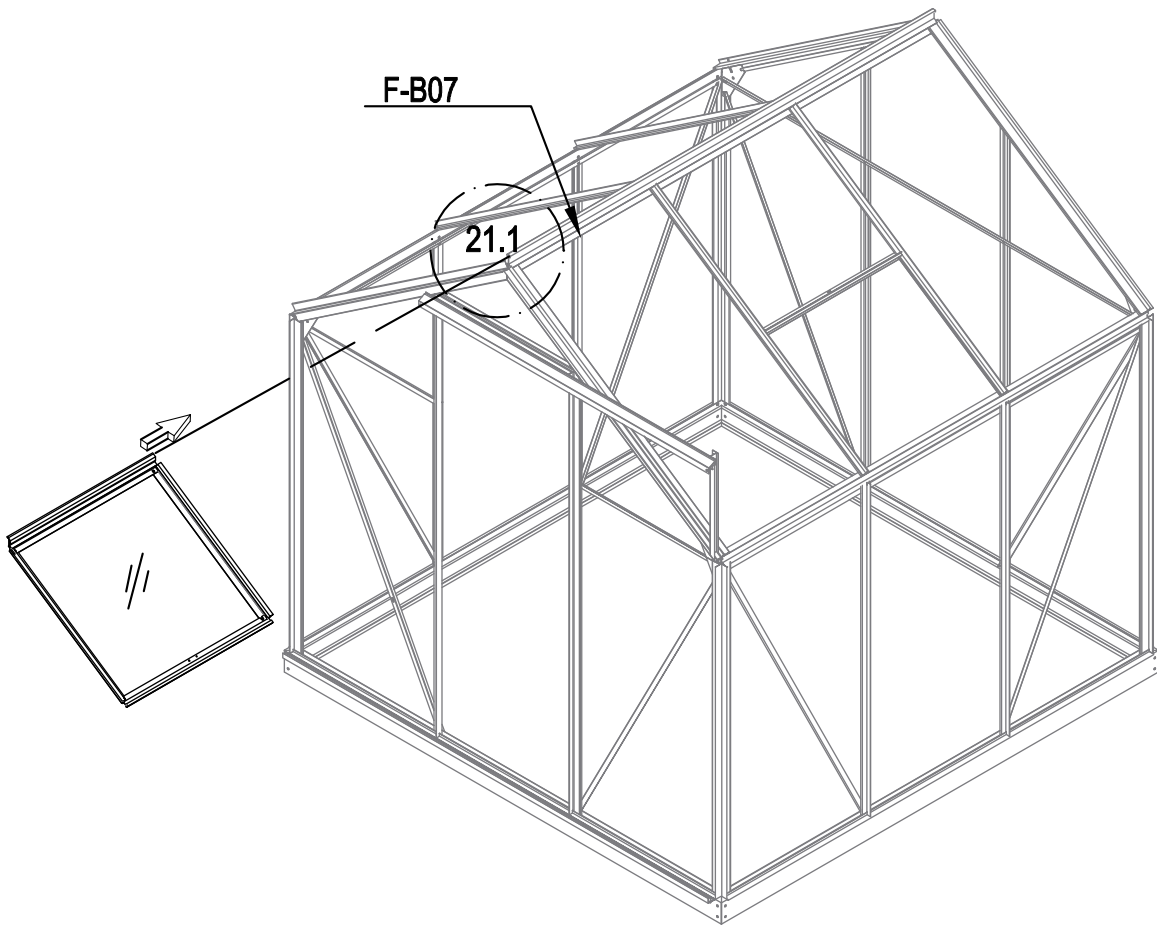

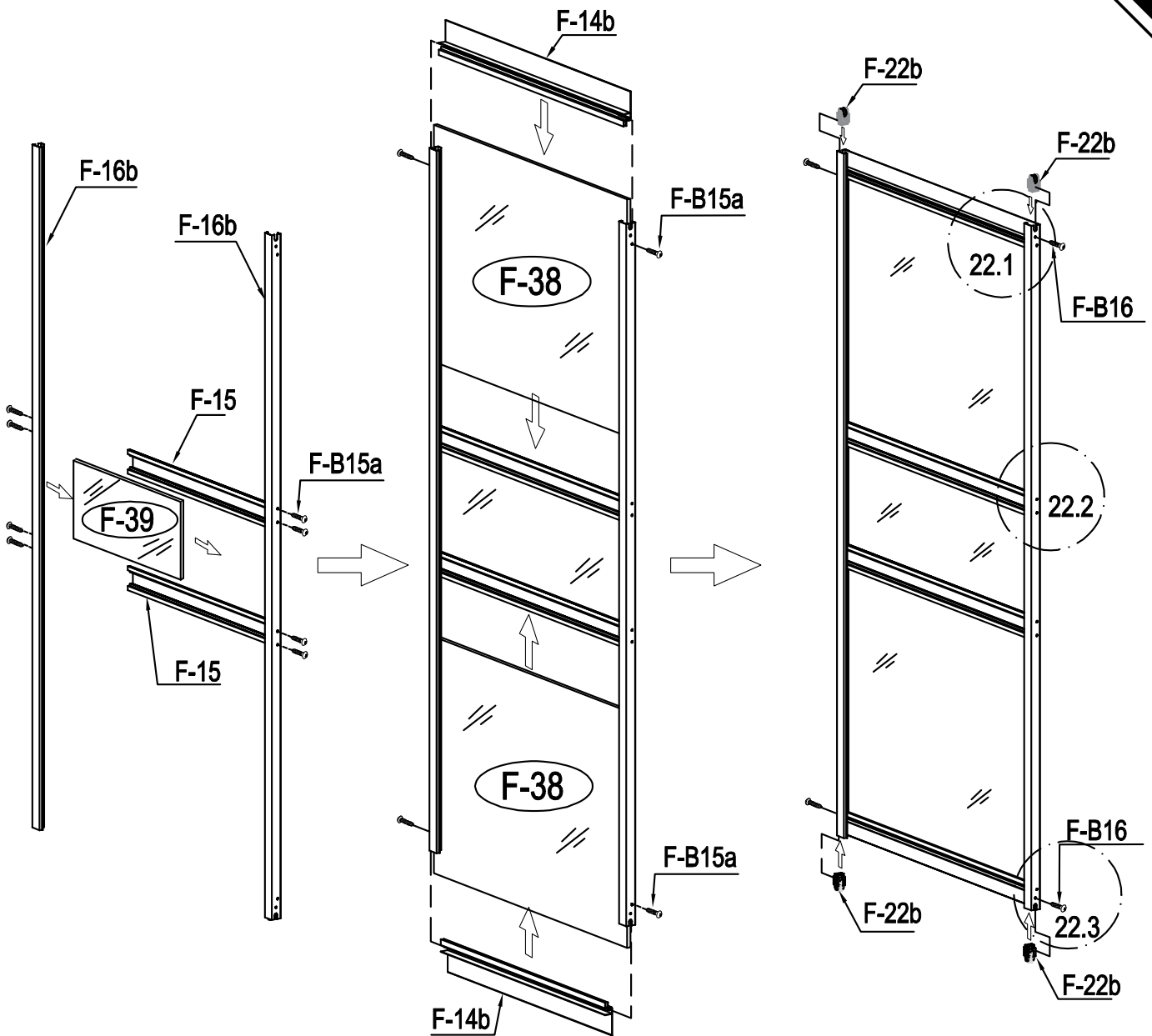



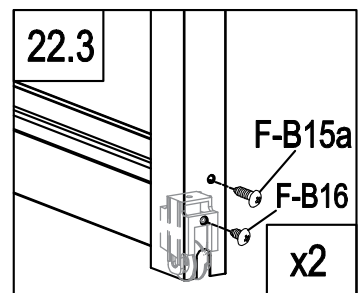
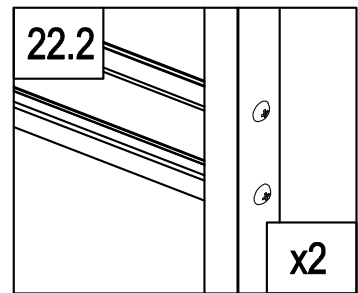
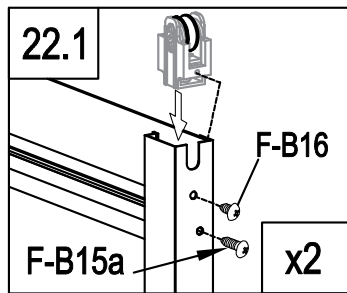

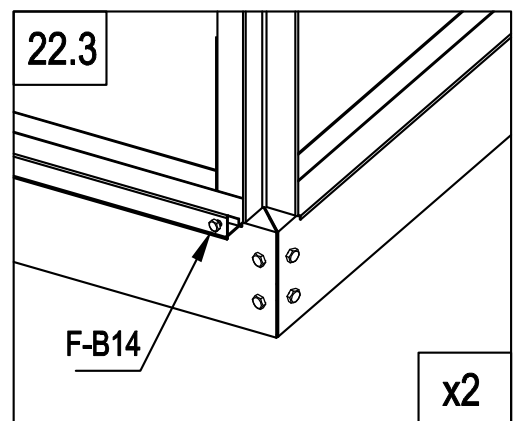
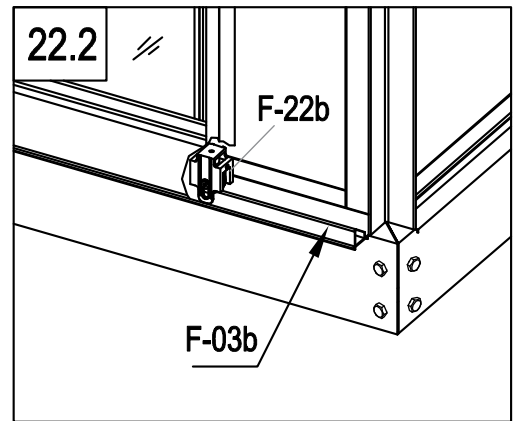
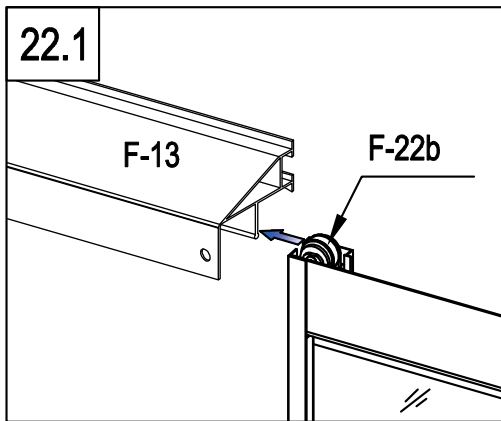
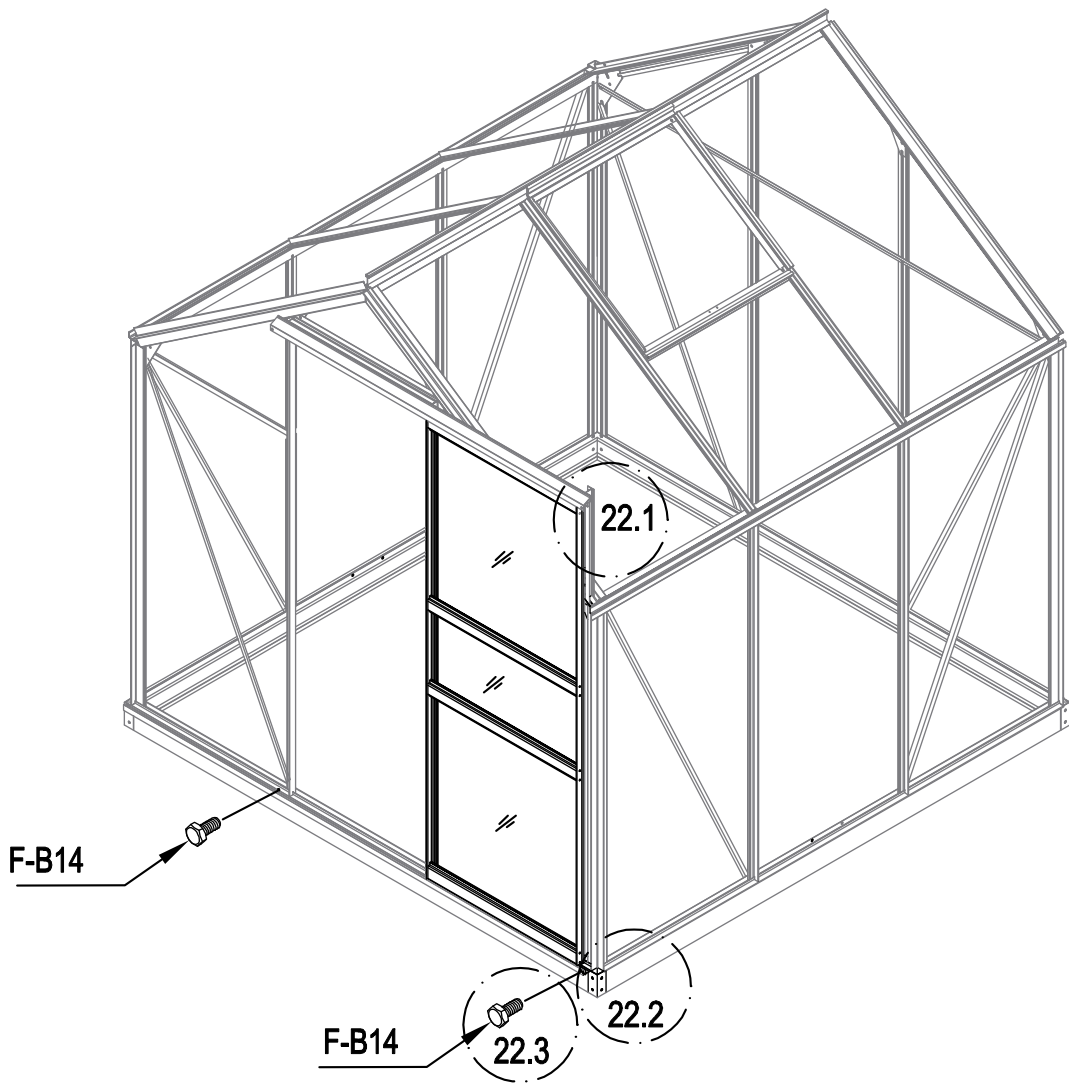



	F-38	2
	F-39	1
	F-16b	2
	F-14b	2
	F-15	2
	F-22b	4
	F-B15a	12
	F-B16	4

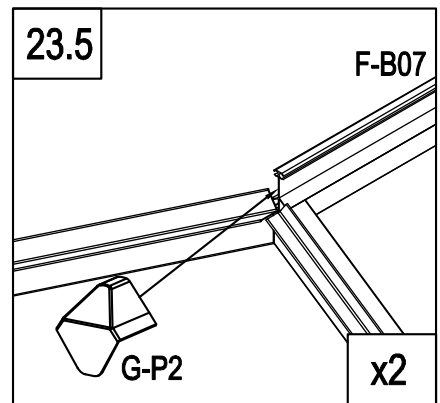
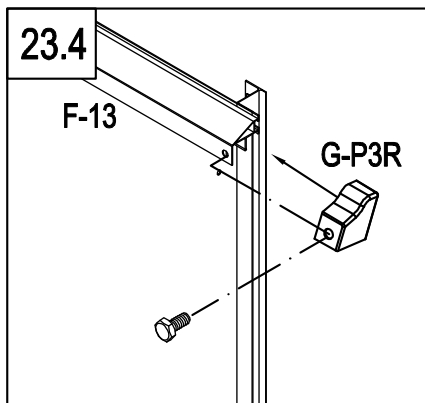
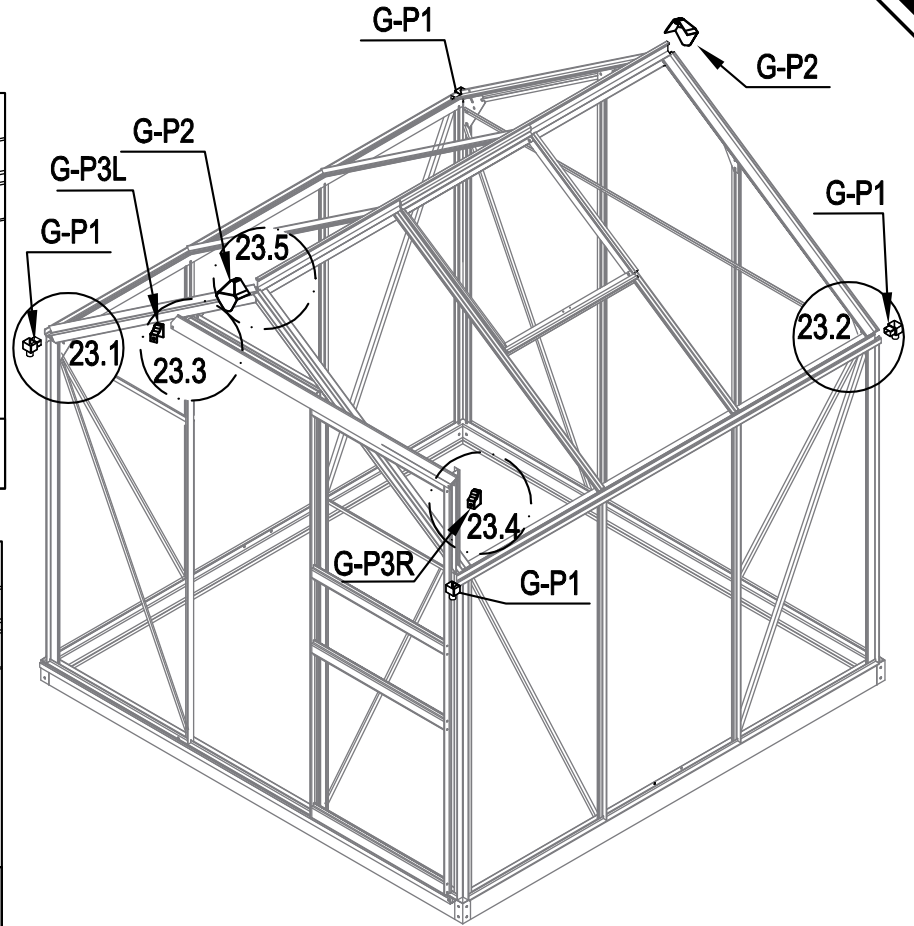
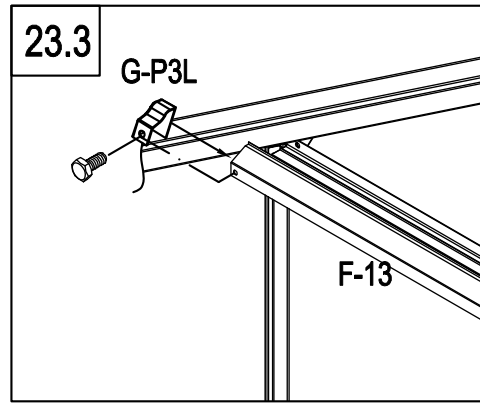
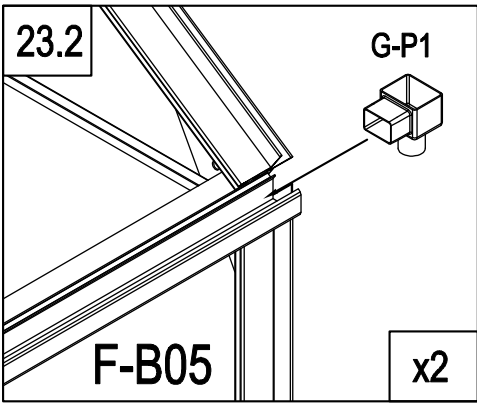
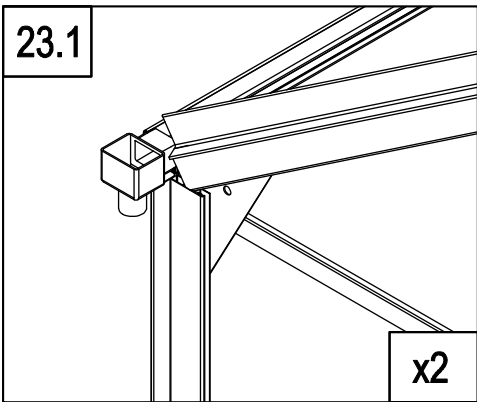
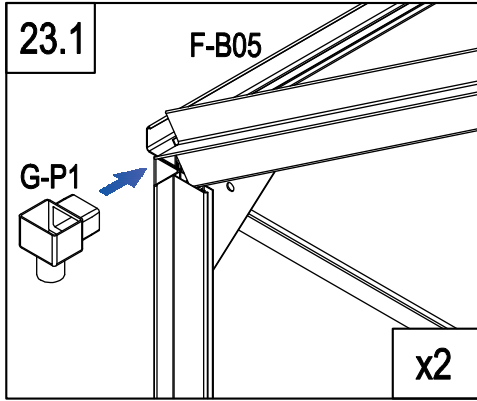



	F-B14	2
---	-------	---



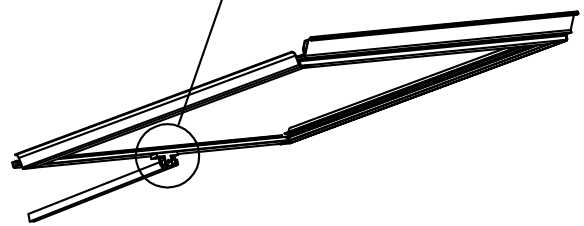
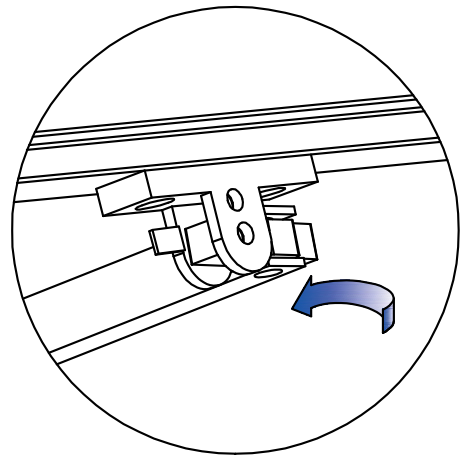
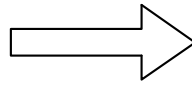
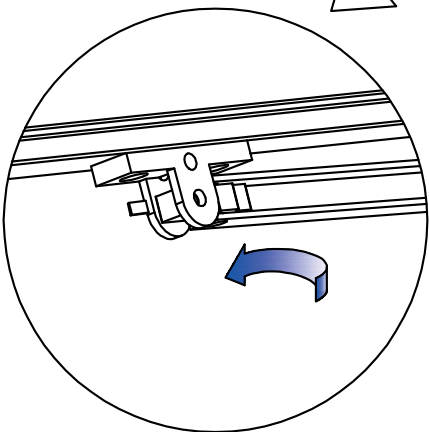
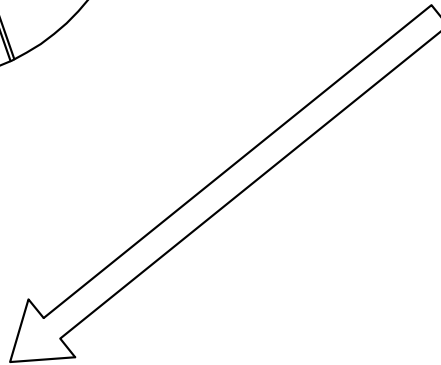
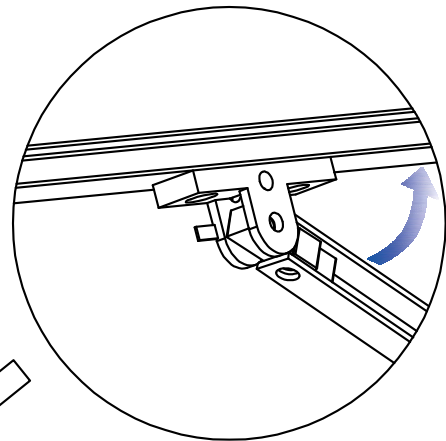
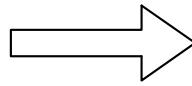
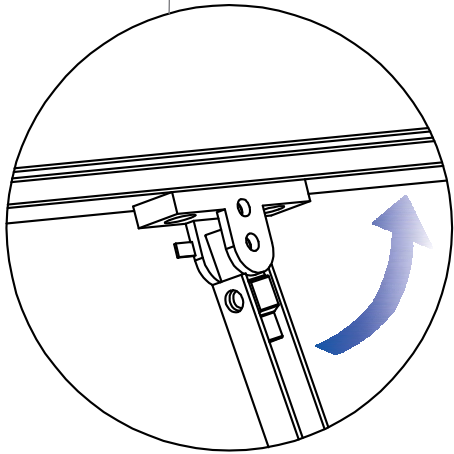
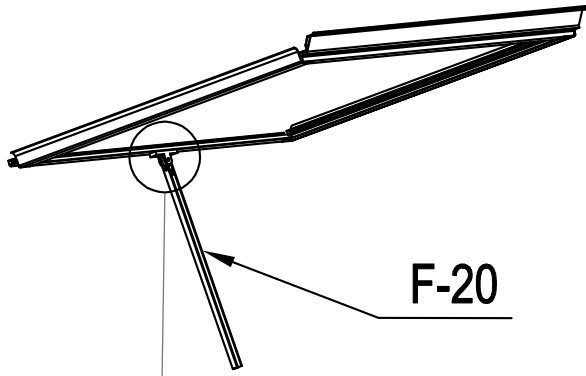

	G-P1	4
	G-P2	2
	G-P3L	1
	G-P3R	1
	F-B14	2

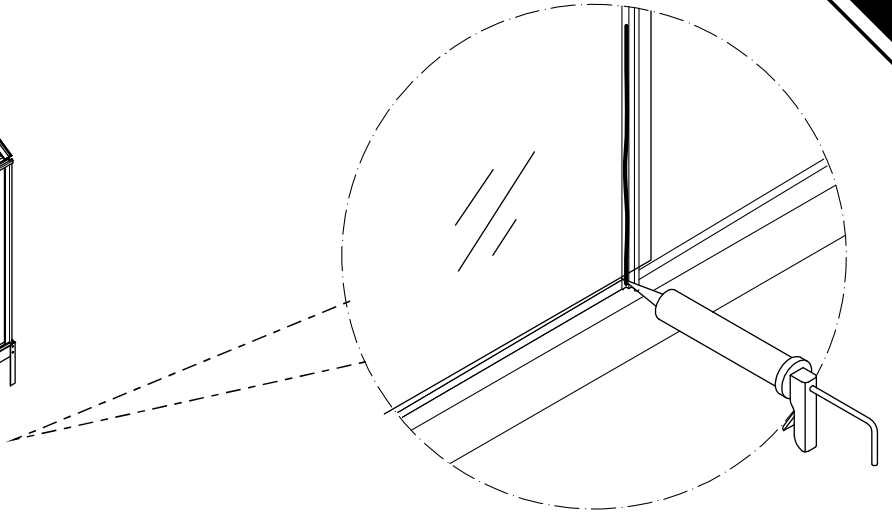
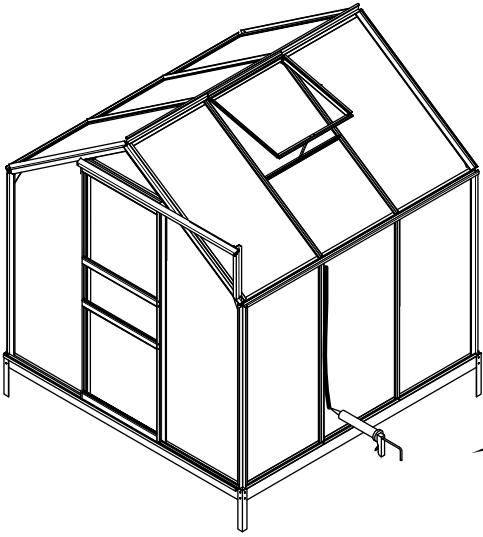

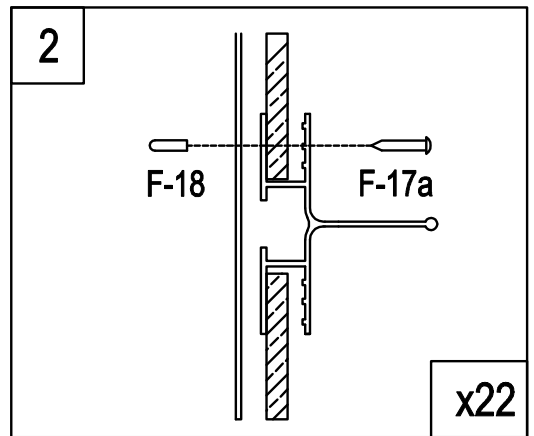
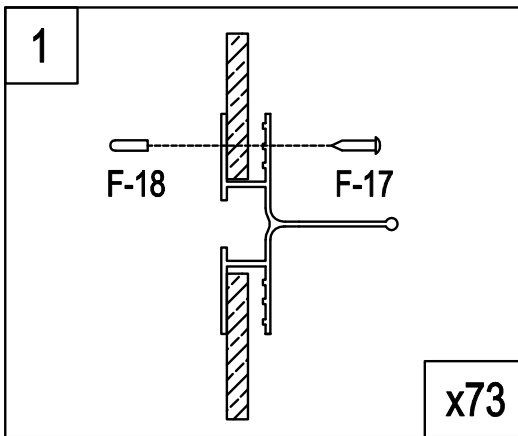
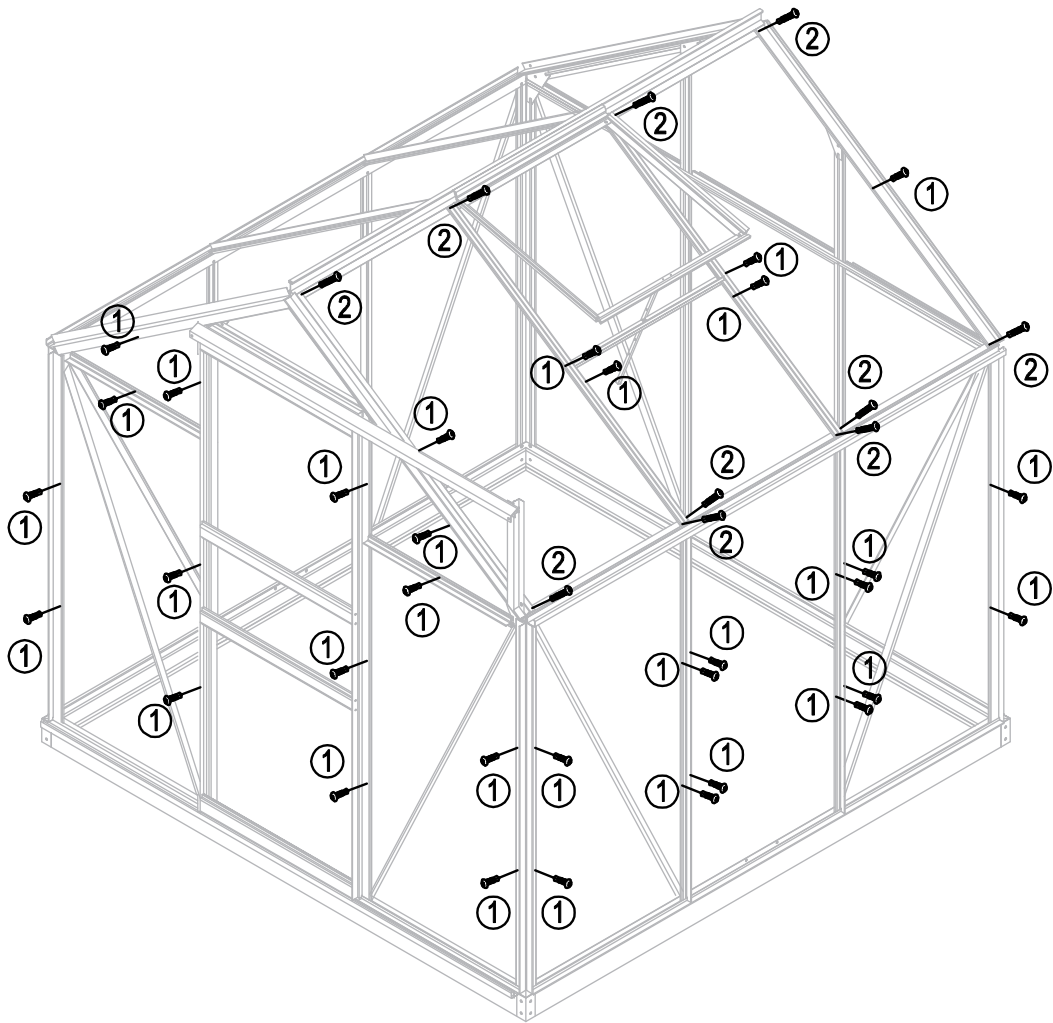



	F-18	95
	F-17	73
	F-17a	22